

PLAYGROUND SPIELPLATZ

GIOCO AIRE DE JEUX

(368 x 370 x h262cm)

003_09900_07122025

MaxPlay 5

INSTALLATION INSTRUCTIONS
MONTAGEANLEITUNG

ISTRUZIONI DI MONTAGGIO
GUIDE D'INSTALLATION

Warranty period - 2 years from purchase date
Garantiezeit - 2 Jahre ab Kaufdatum

Periodo di garanzia - 2 anni dalla data di acquisto
Période de garantie - 2 ans à compter de l'achat

EN - 71

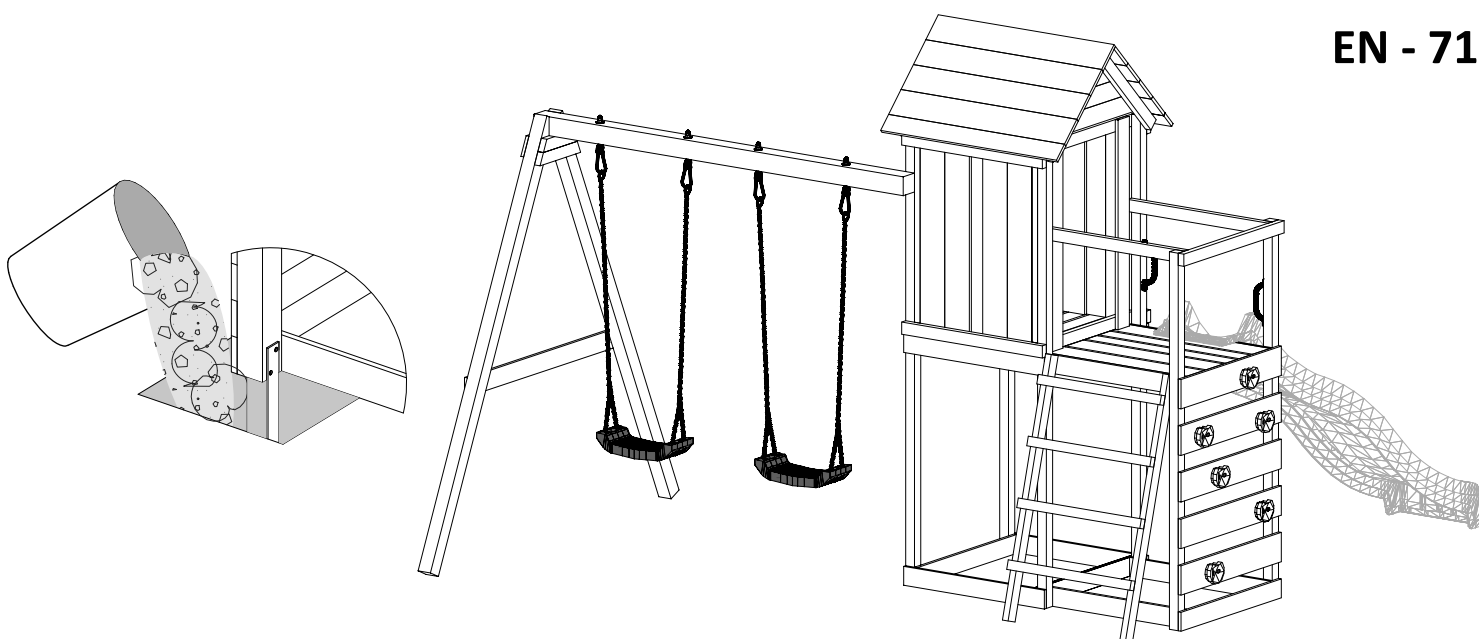

WARNINGS!

Only for home use.
Dedicated for external use only.
Not suitable for children under 3 years old.
Risk of falling down and/or hitting.
Maximum user weight is up to 50 kg.
Maximum number of users staying on the
playground at the same time: 8.

ACHTUNG!

Nur für den privaten, häuslichen Bereich.
Ausschließlich für die Verwendung im Freien.
Nicht geeignet für Kinder unter 3 Jahren.
Stolper- und / oder Sturzgefahr
Höchstgewicht pro Einzelkind beträgt 50 kg
Der Aufenthalt auf diesem Spielturm ist max. : 8.
Kindern gleichzeitig erlaubt.

ATTENZIONE!

Solo per uso domestico.
Articolo per uso esterno.
Previsto per bambini di età superiore ai 3 anni.
Pericolo di caduta, e/o impatto.
Peso massimo di utente : 50kg
Numero massimo di utilizzatori
del gioco nello stesso momento: 8.

AVERTISSEMENT!

Aire exclusivement destinée à un usage privé.
Aire exclusivement destinée à un usage en extérieur.
Prévue pour les enfants de plus de 3 ans.
Danger de chute ou de choc.
Poids maximal d'un utilisateur : 50 kg.
Nombre maximal d'utilisateurs présents en
même temps sur la même aire de jeux: 8.

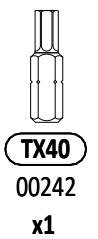
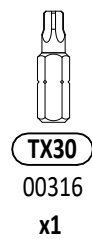
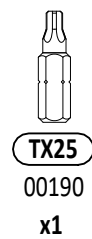
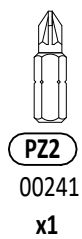
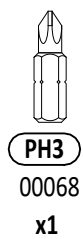
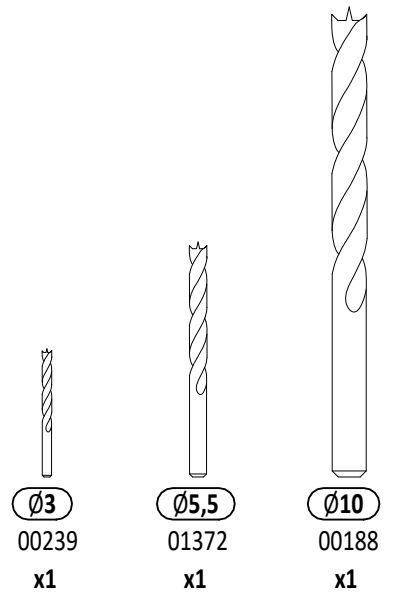
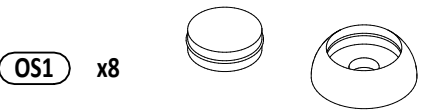
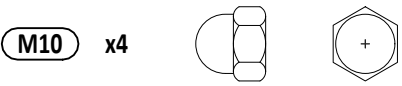
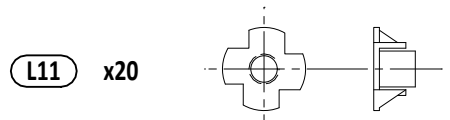
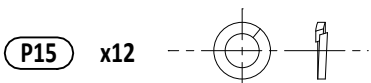
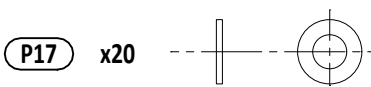
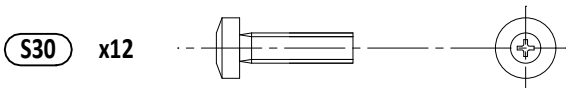
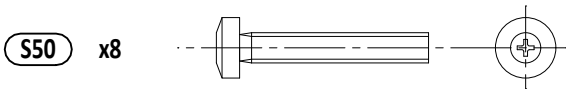
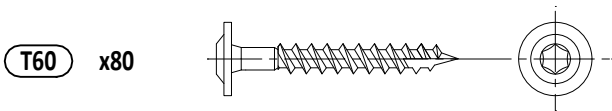
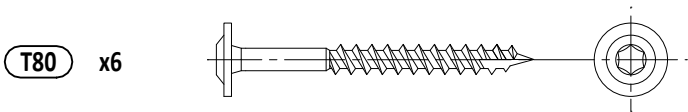
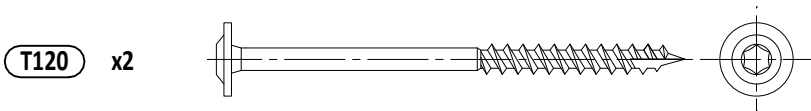
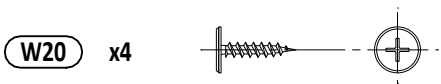
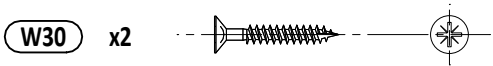
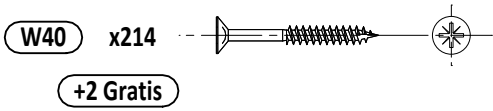
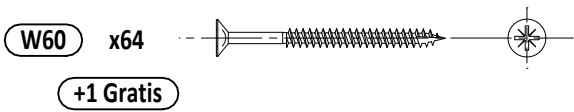
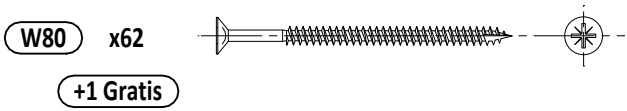

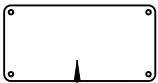
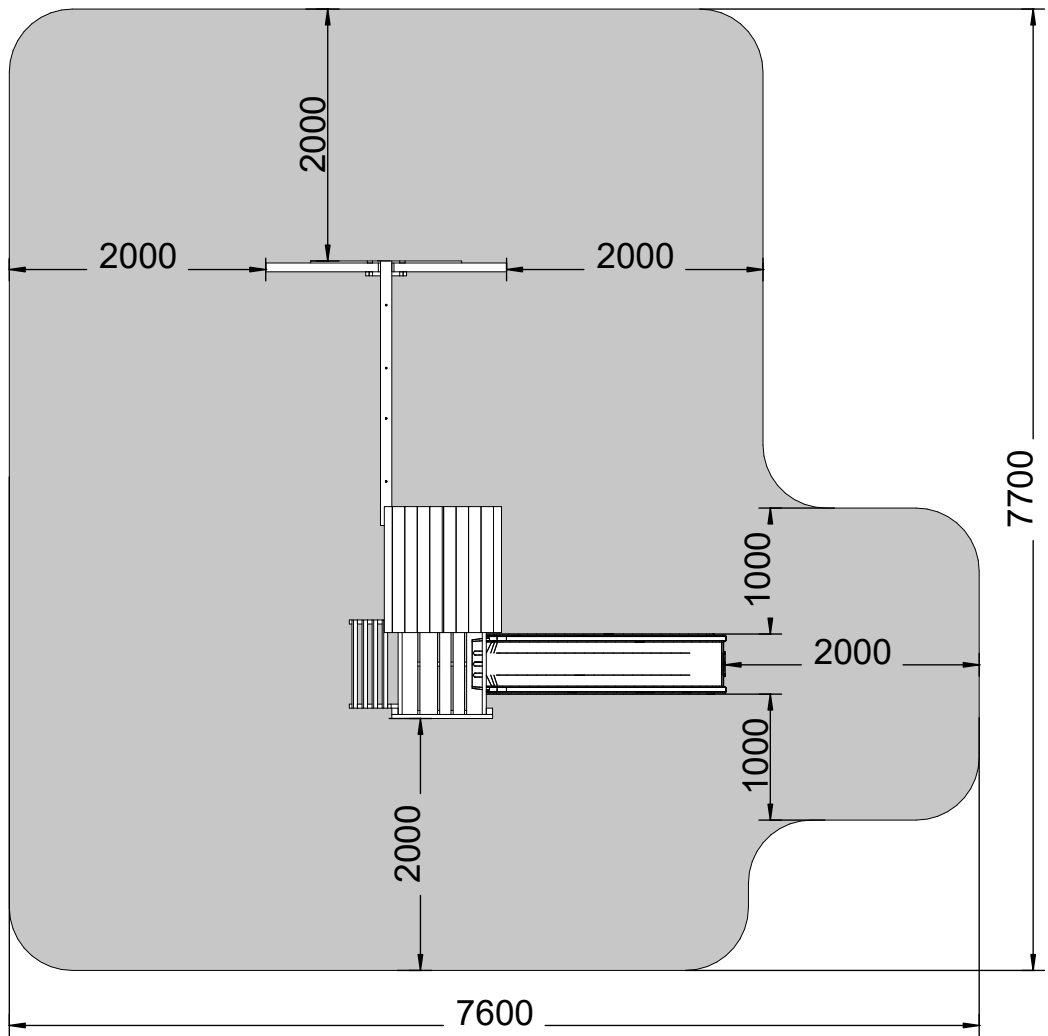

PLT x1
00197

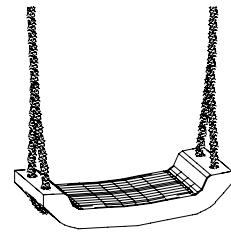

SE x2
00001



SW x6
00246

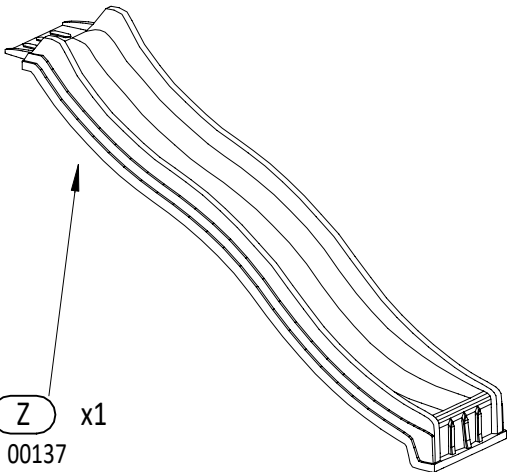

Z x1
00137

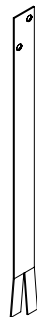

MG x6
00199



UC x2
00090



ZK x4
00347

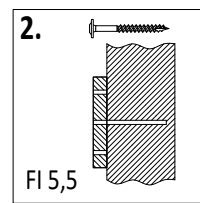
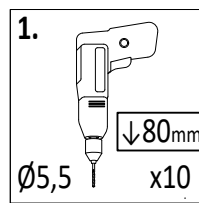
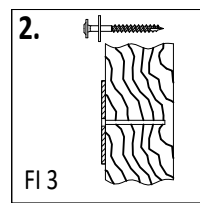
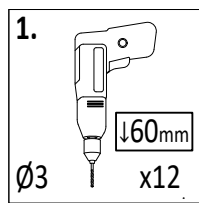
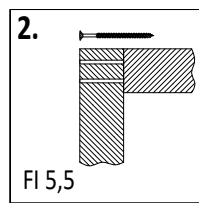
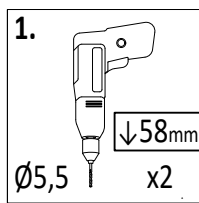
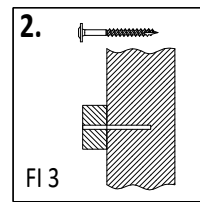
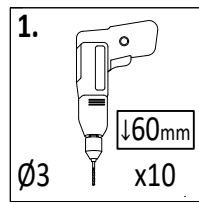
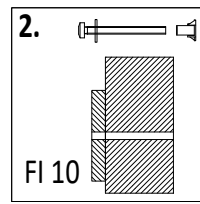
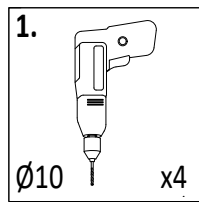
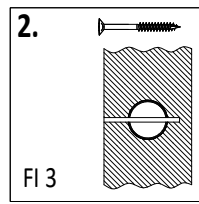
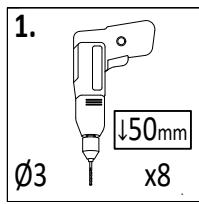
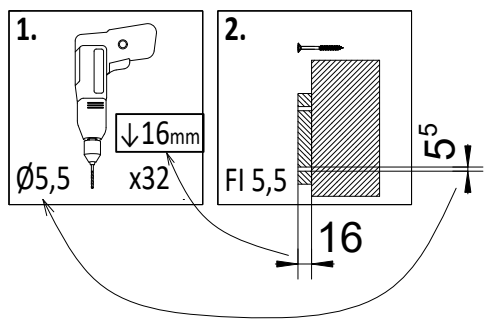
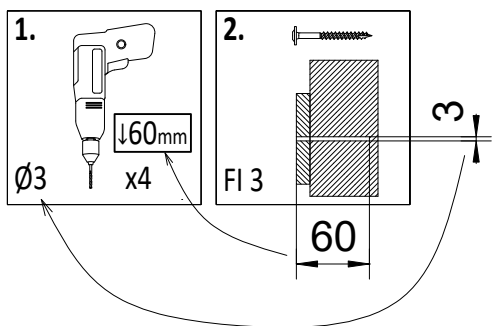
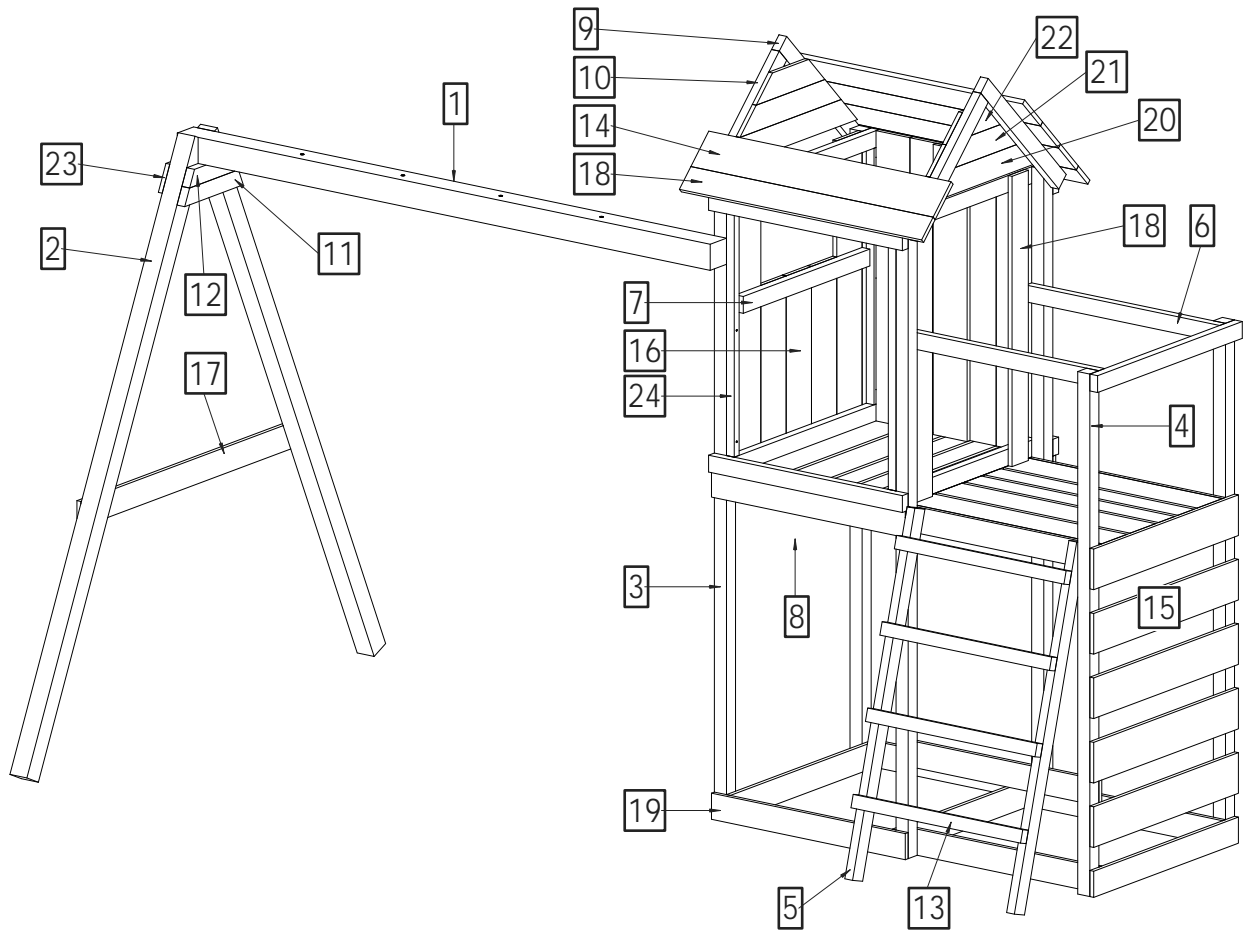

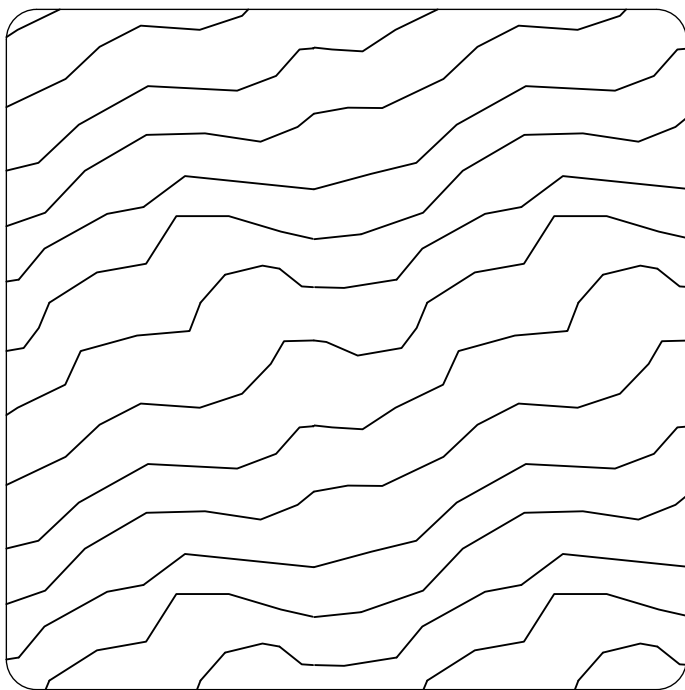

9 x 9 cm

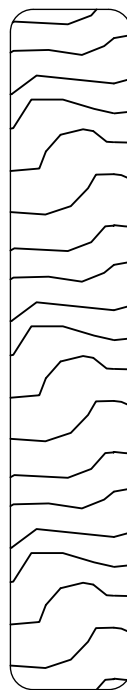

1,6 x 9,0 cm

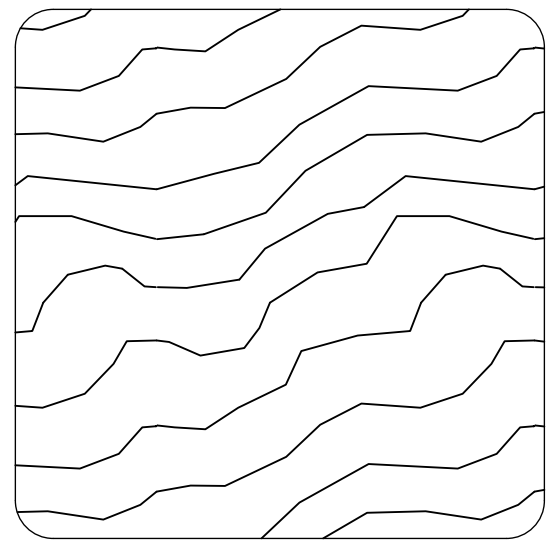

7,0 x 7,0 cm

1,6 x 14,0 cm

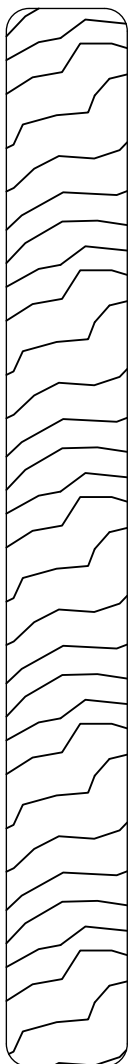

Lp.	Kod	Wymiary [mm]	szt.
1a	09803	90x90x2200mm	1
2a	06453	70x70x2200mm	2
3	09805	50x50x2200mm	4
4	09809	50x50x1800mm	2
5	05908	32x58x1250mm	2
6	04457	32x58x800mm	11
7	05219	32x58x700mm	1
8	09807	32x58x668mm	6
9	04617	32x58x610mm	2
10	04619	32x58x550mm	2
11a	05177	32x58x324mm	1
12a	05179	32x58x270mm	1
13	05709	32x45x700mm	4
14	09827	16x140x1000mm	20
15	09815	16x140x800mm	11
16	09821	16x140x600mm	3
17	04645	16x90x1200mm	1
18	04503	16x90x1000mm	4
19	04465	16x90x800mm	18
20a	04546	16x90x740mm	2
21a	04467	16x90x560mm	2
22a	04548	16x90x380mm	2
23a	05187	16x90x300mm	1
24a	09829	27x32x884mm	4

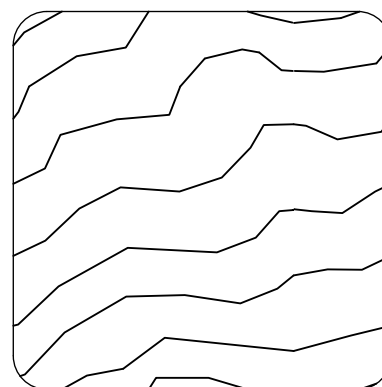

5,0 x 5,0 cm

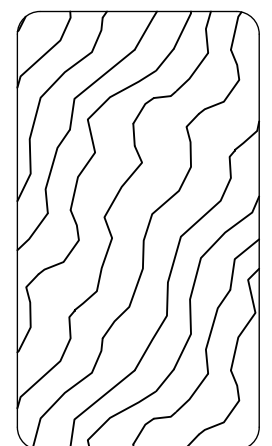

3,2 x 5,8 cm

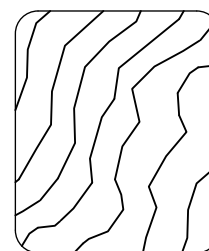

2,7 x 3,2 cm

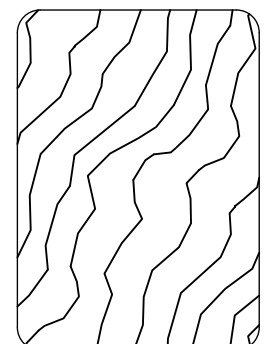

3,2 x 4,5 cm

1a

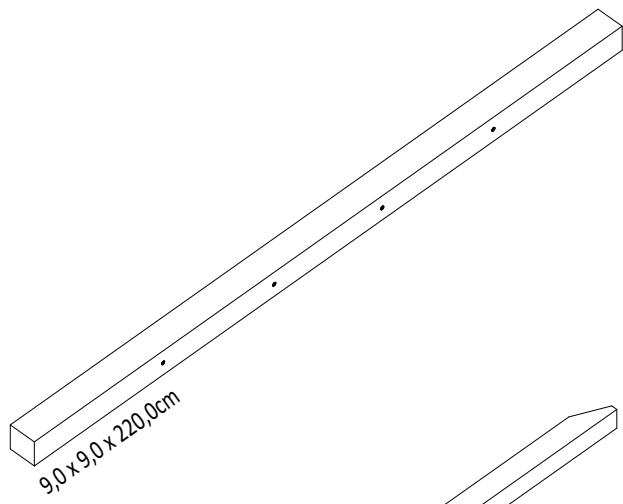

2a

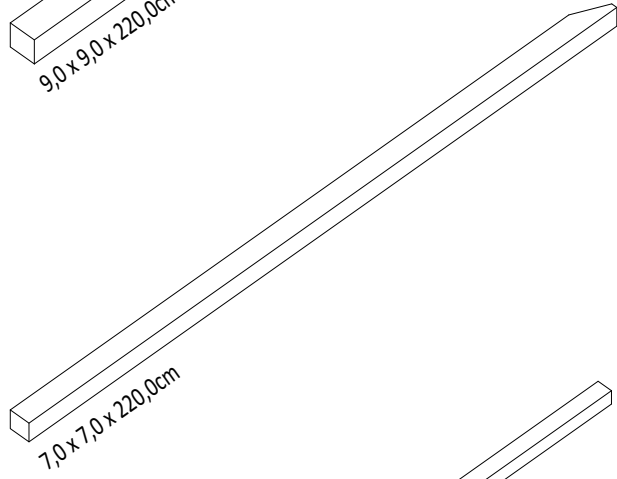

3

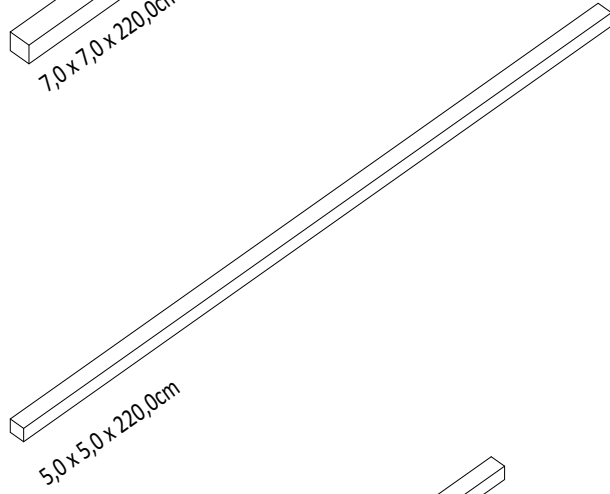

4

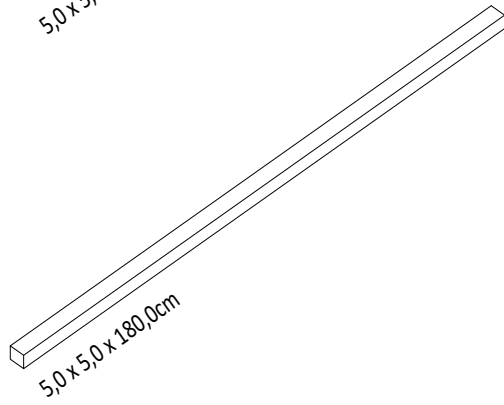

5

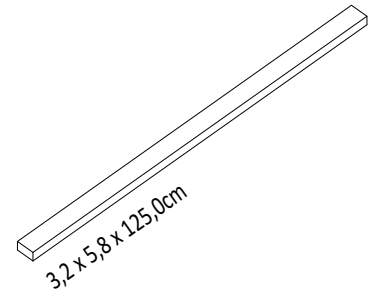

6

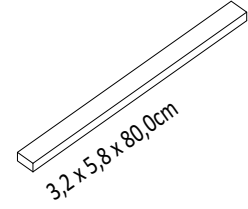

7

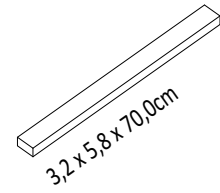

8

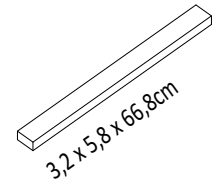

9

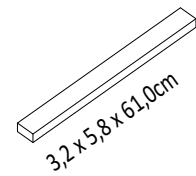

10

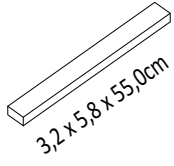

15

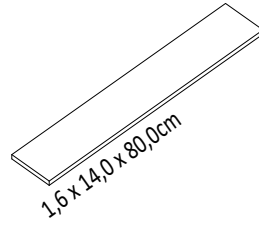

20a

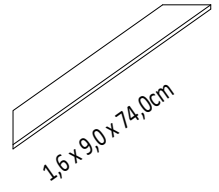

11a

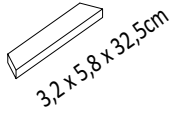

16

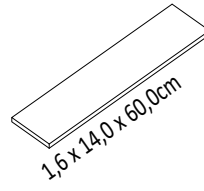

21a

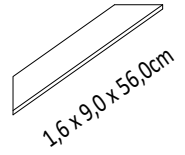

12a

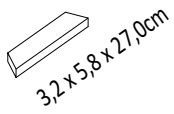

17

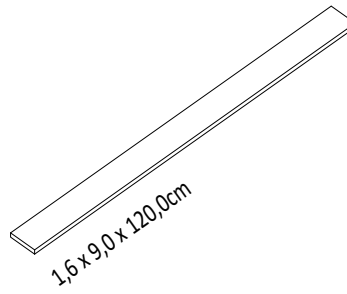

22a

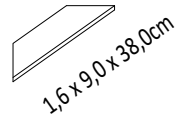

13

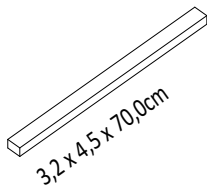

18

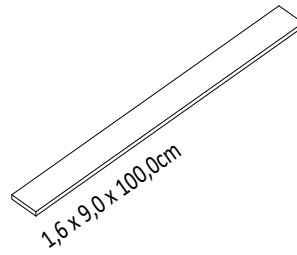

23a

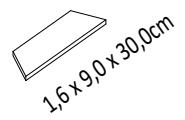

14

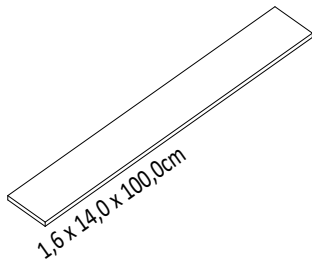

19

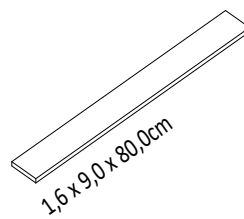

24a

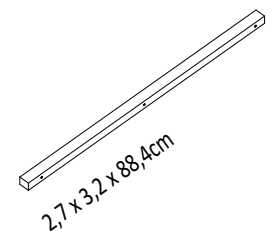

01

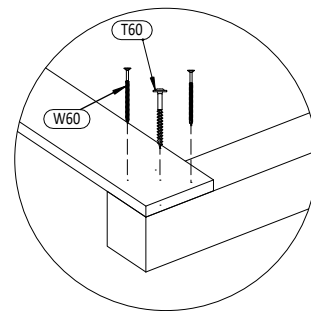
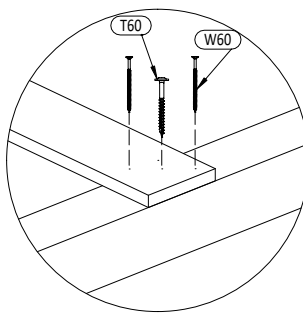
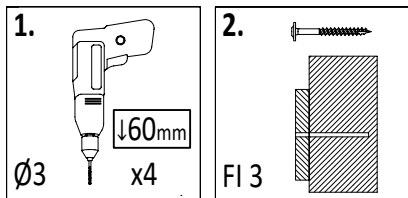

!! x2

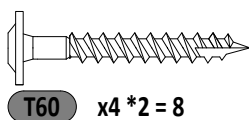
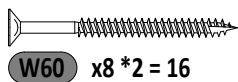
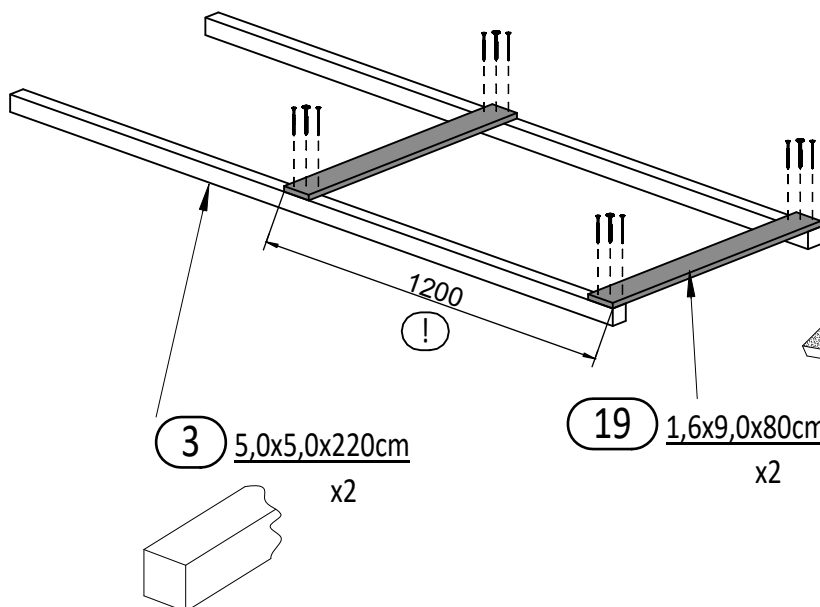

02

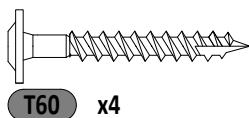
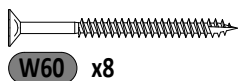
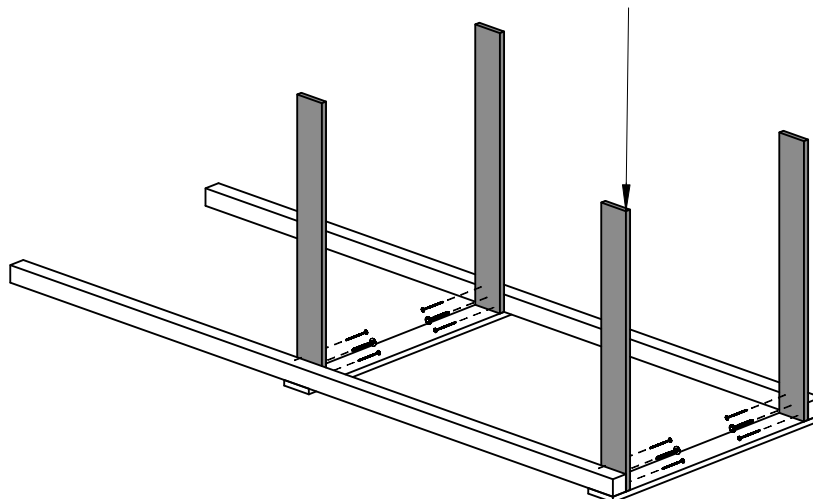
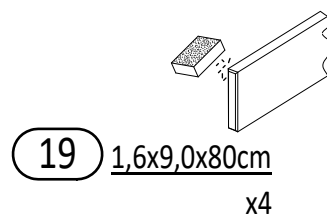
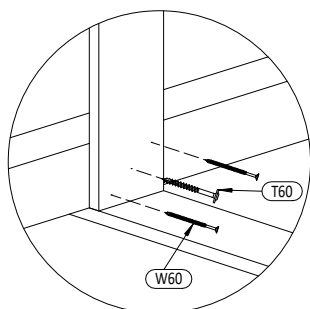
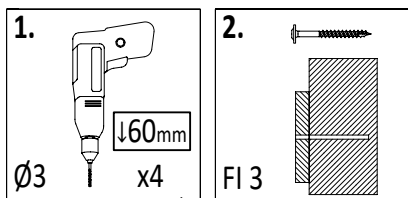

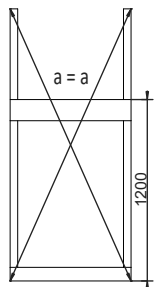
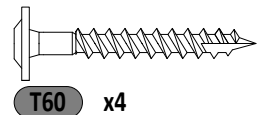
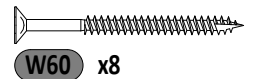
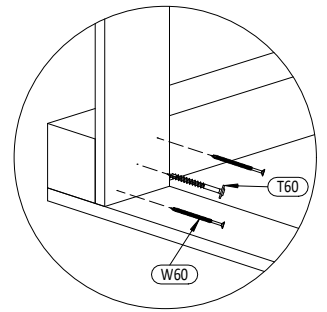
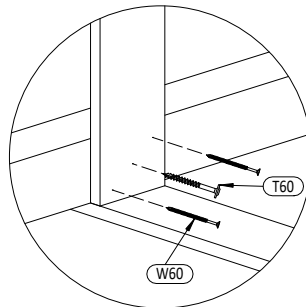
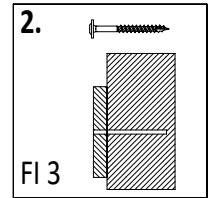
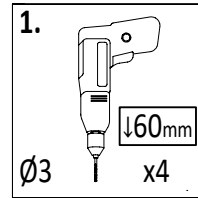
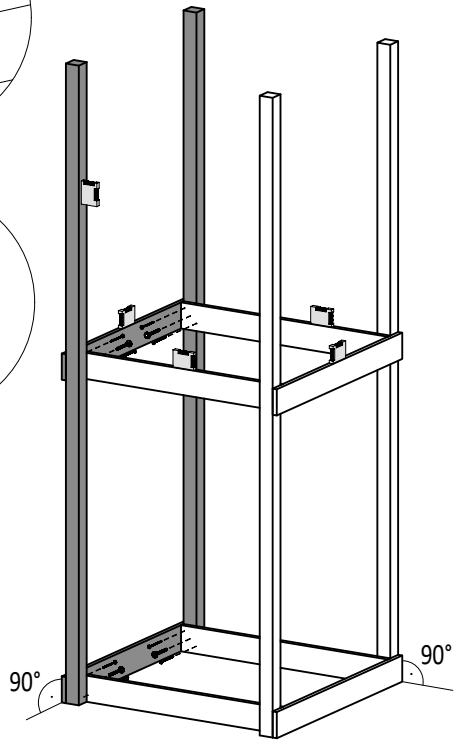
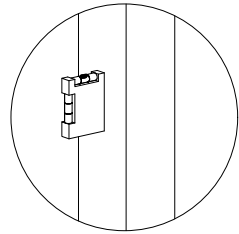
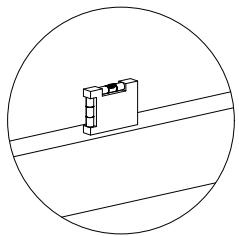

15 1,6x14,0x80cm
x1

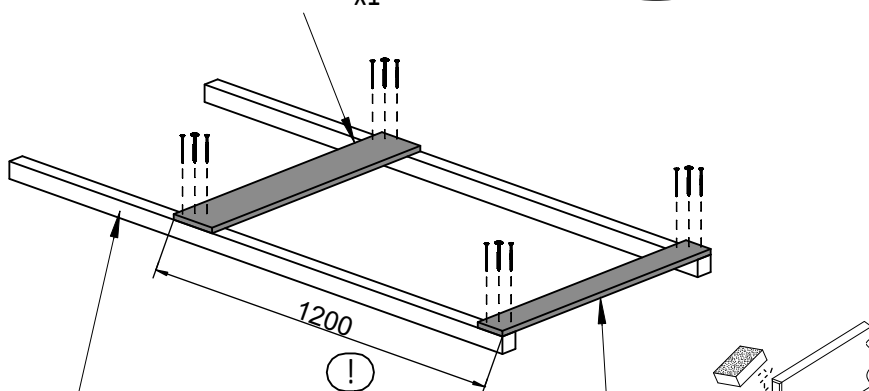
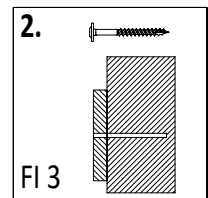
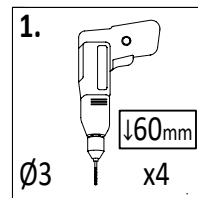
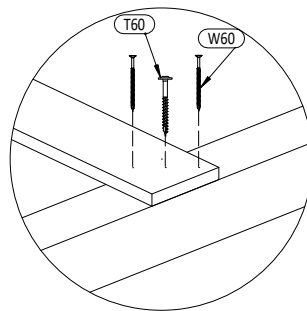

4 5,0x5,0x180cm
x2

19 1,6x9,0x80cm
x1

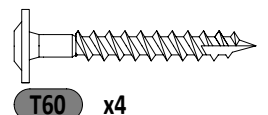
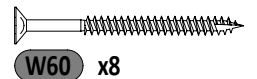
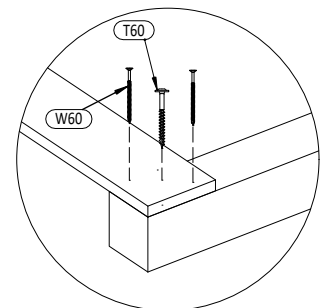

Zgodnie z normą PN-EN 71 stosuj zalecenia producenta odnośnie odległości oraz metody mocowania poszczególnych elementów

In compliance with the standard PN-EN 71, apply guidelines of the producer in relation to distances and methods of fastening individual elements

05

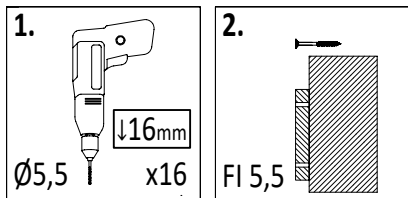

15 1,6x14,0x80cm
x4

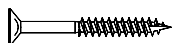
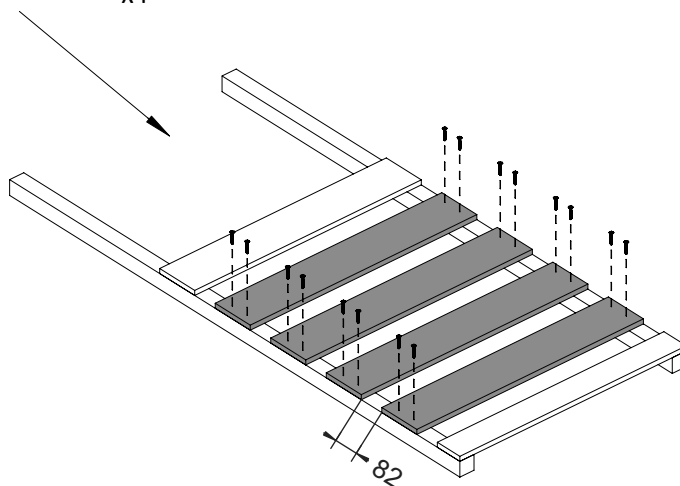
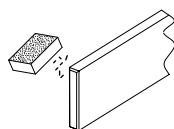

W40 x16

06

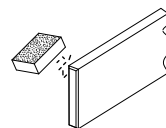
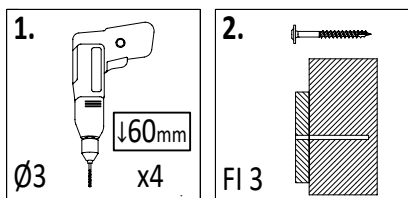

19 1,6x9,0x80cm
x4

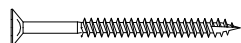
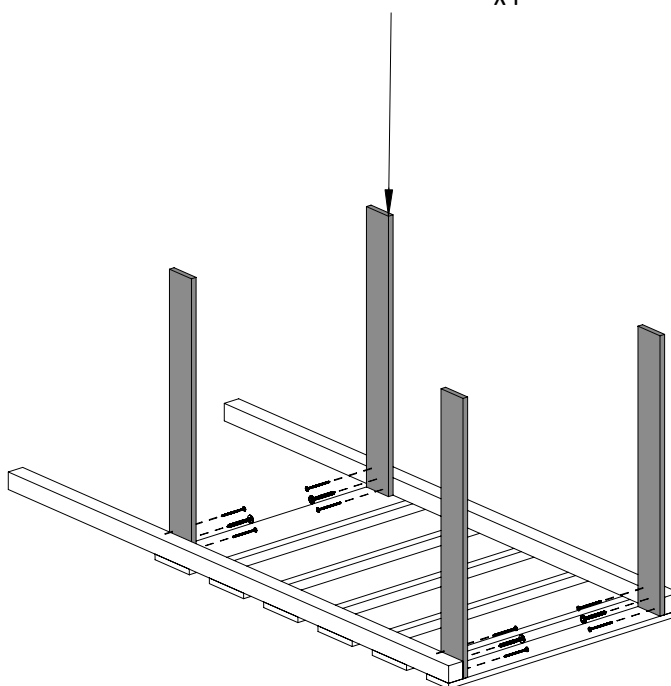
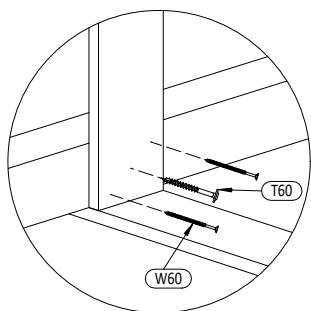

W60 x8

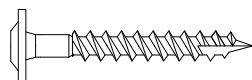

T60 x4

10 MaxPlay 3

Zgodne z normą PN-EN 71 stosuj zalecenia producenta odnośnie odległości oraz metody mocowania poszczególnych elementów
In compliance with the standard PN-EN 71, apply guidelines of the producer in relation to distances and methods of fastening individual elements

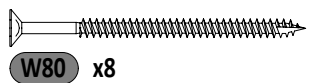
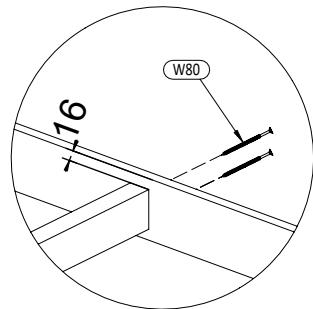
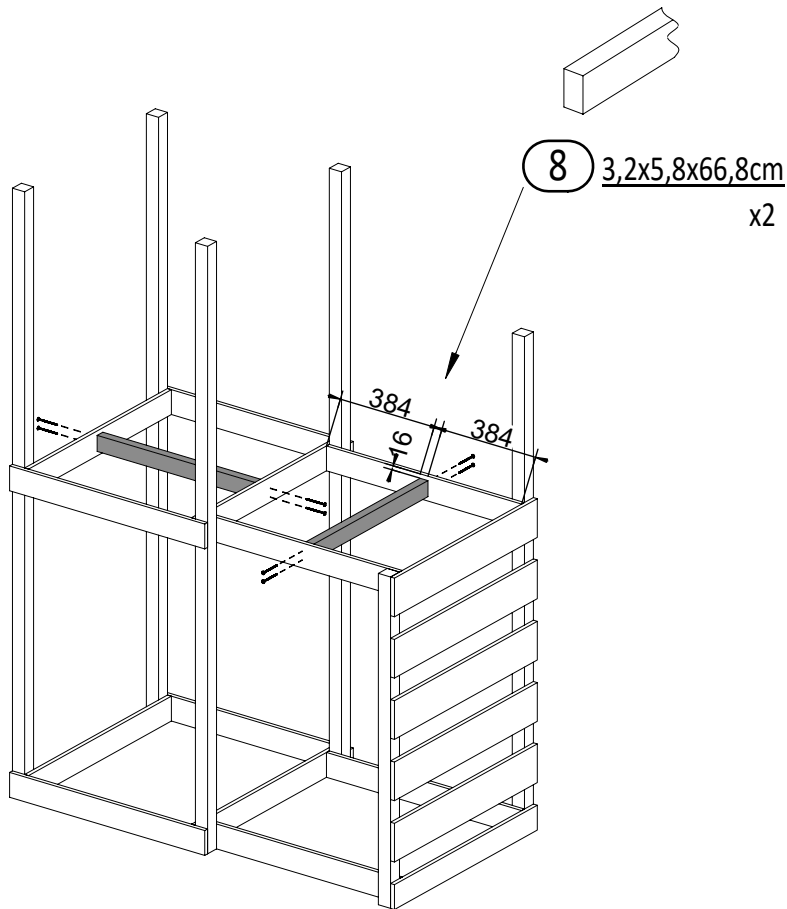
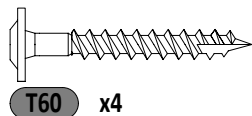
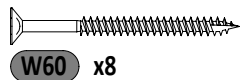
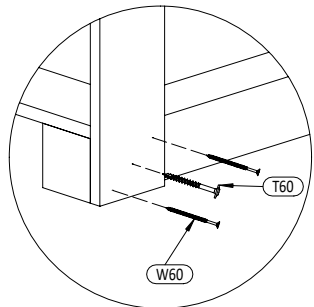
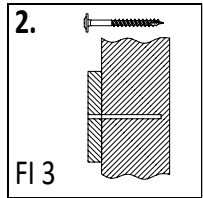
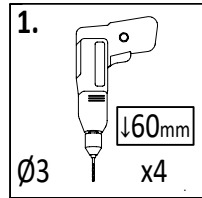
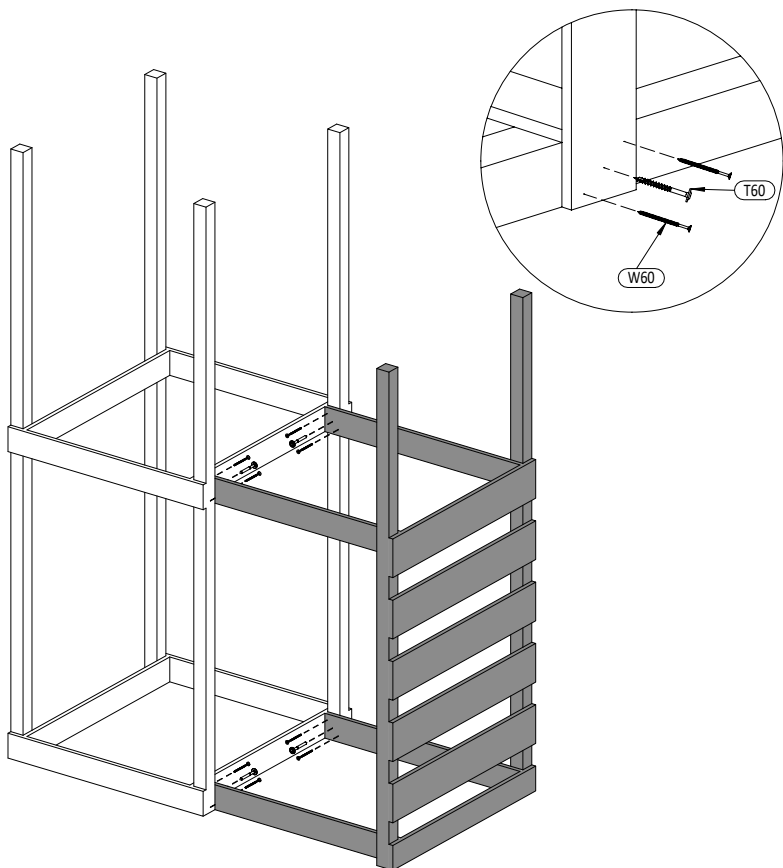

09

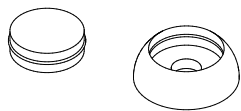
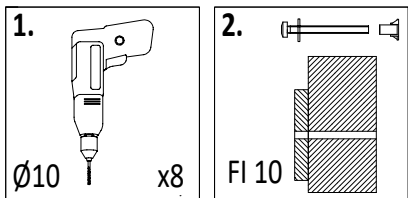

OS1 x8

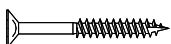

W40 x8

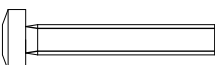

S50 x8



P17 x8



L11 x8

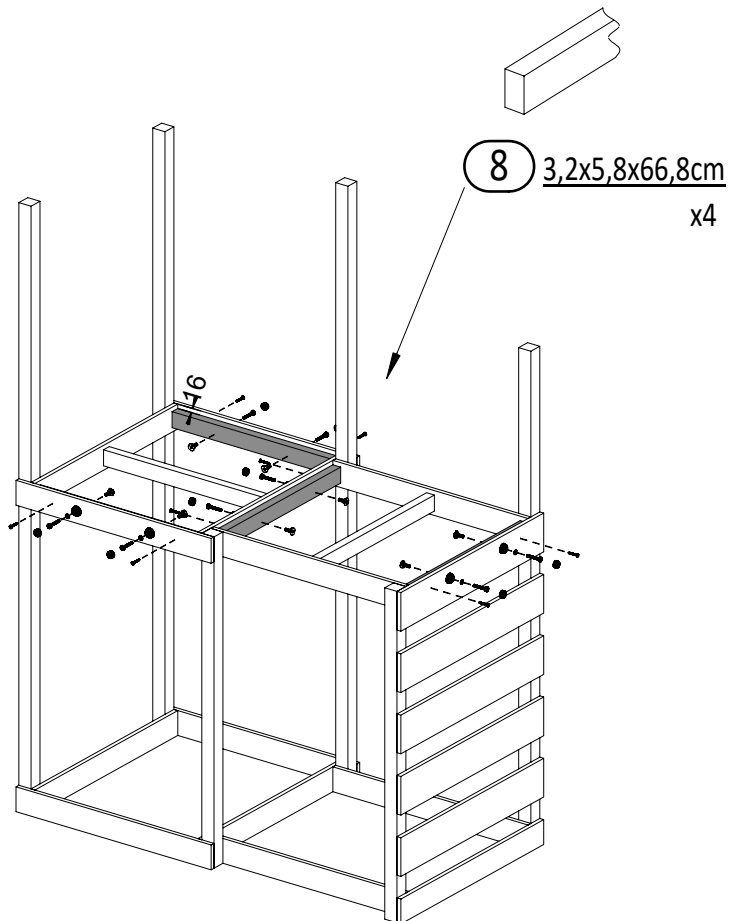
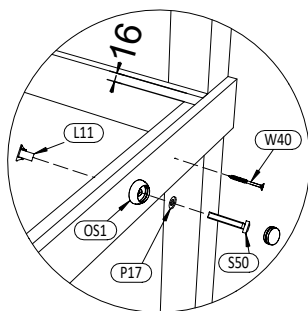

10

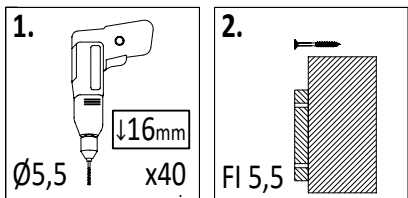

15 1,6x4,0x80cm
x3 * 2 = 6

19 1,6x9,0x80cm
x2 * 2 = 4

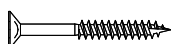
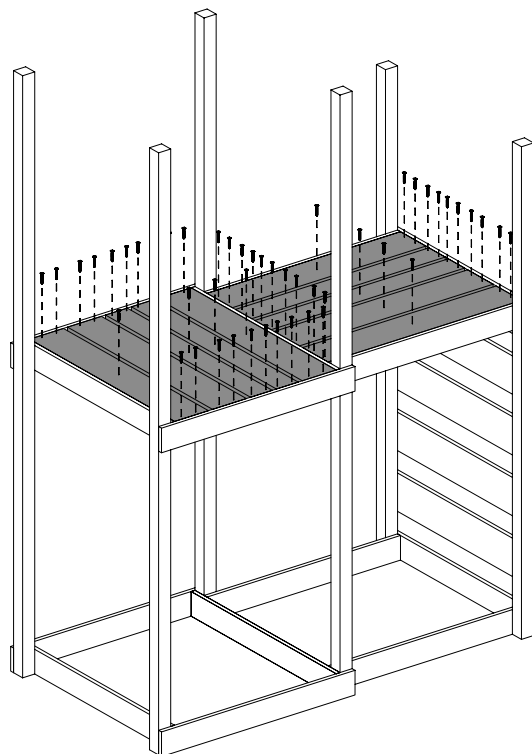
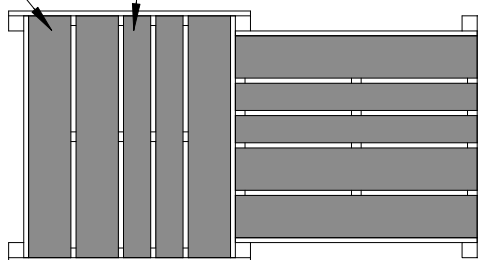
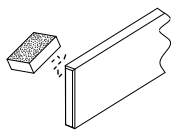

W40 x50

12 MaxPlay 3

Zgodnie z normą PN-EN 71 stosuj zalecenia producenta odnośnie odległości oraz metody mocowania poszczególnych elementów
In compliance with the standard PN-EN 71, apply guidelines of the producer in relation to distances and methods of fastening individual elements

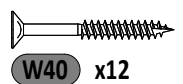
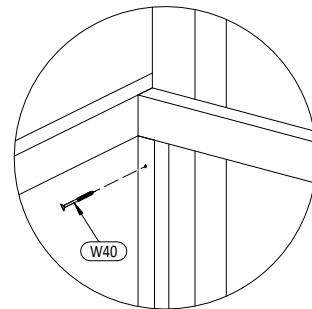
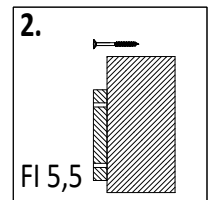
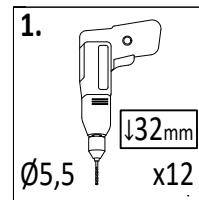
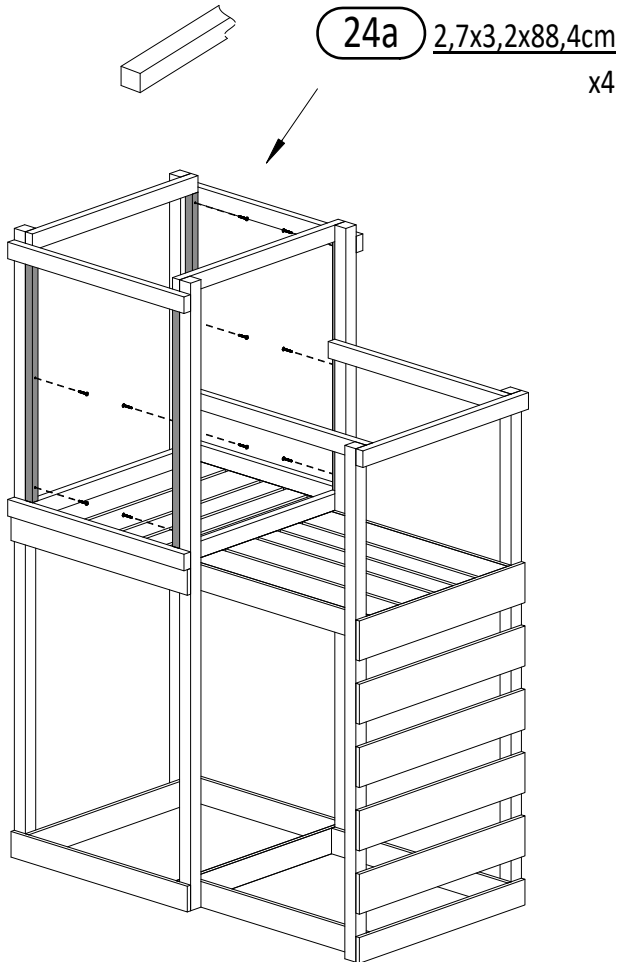
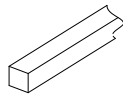
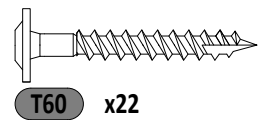
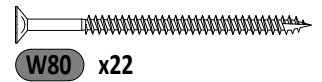
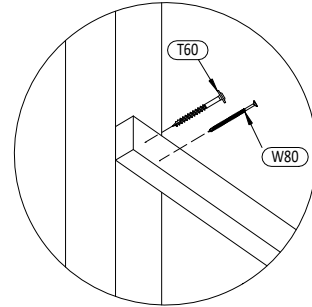
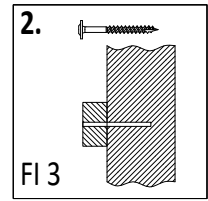
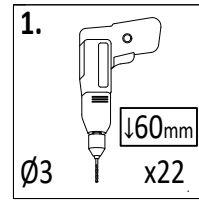
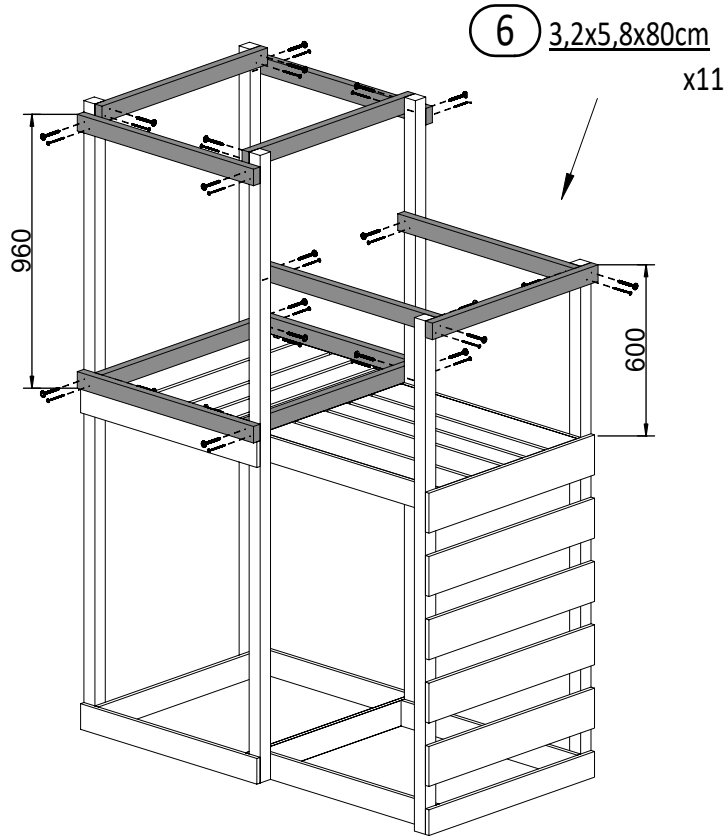
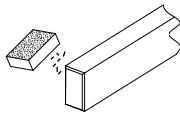

13

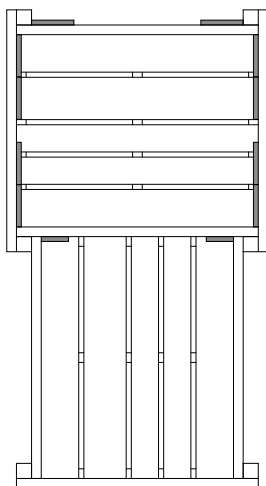
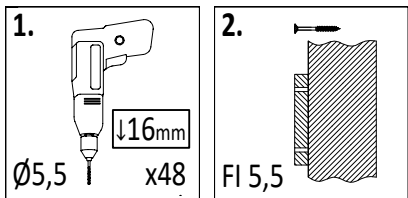

14 1,6x14,0x100cm

x10

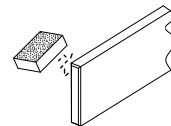

18 1,6x9,0x100cm

x2

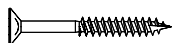
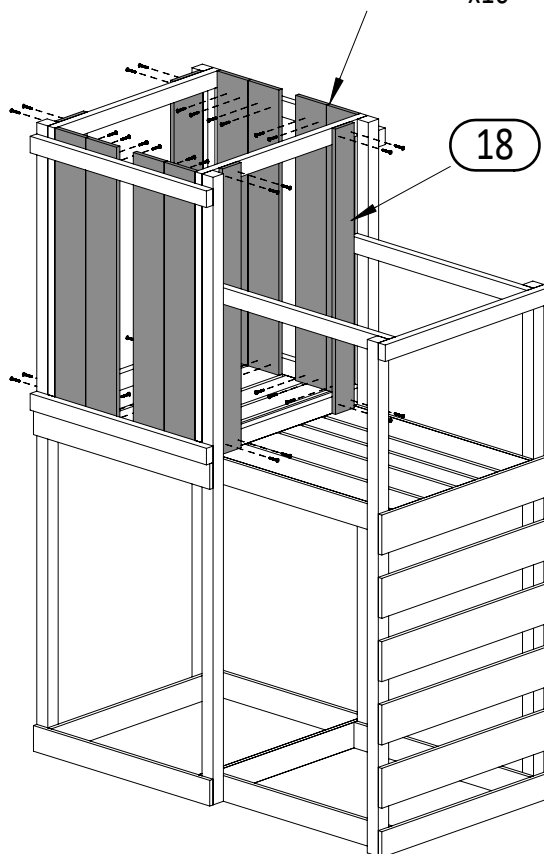

W40 x48

14

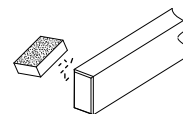
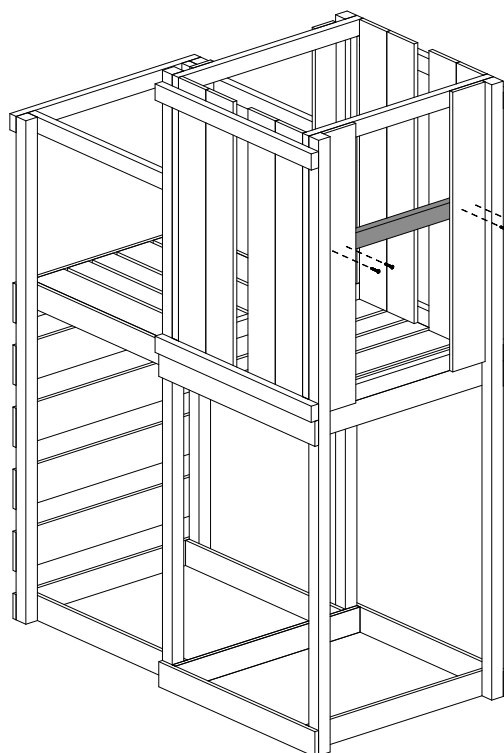
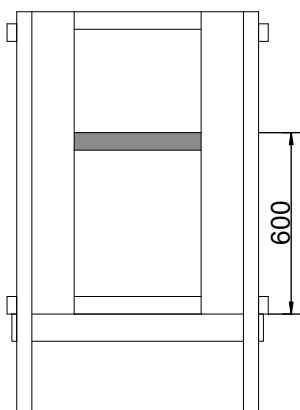
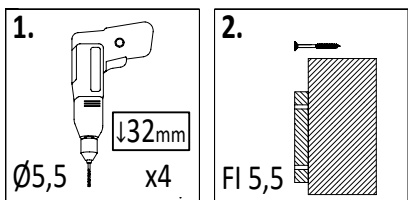

7 3,2x5,8x70,0cm

x1

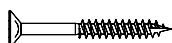

W40 x4

14 MaxPlay 3

Zgodnie z normą PN-EN 71 stosuj zalecenia producenta odnośnie odległości oraz metody mocowania poszczególnych elementów
 In compliance with the standard PN-EN 71, apply guidelines of the producer in relation to distances and methods of fastening individual elements

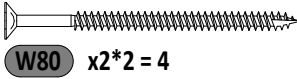
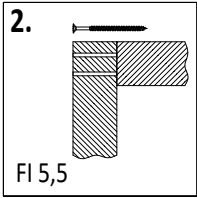
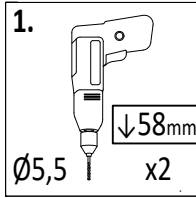
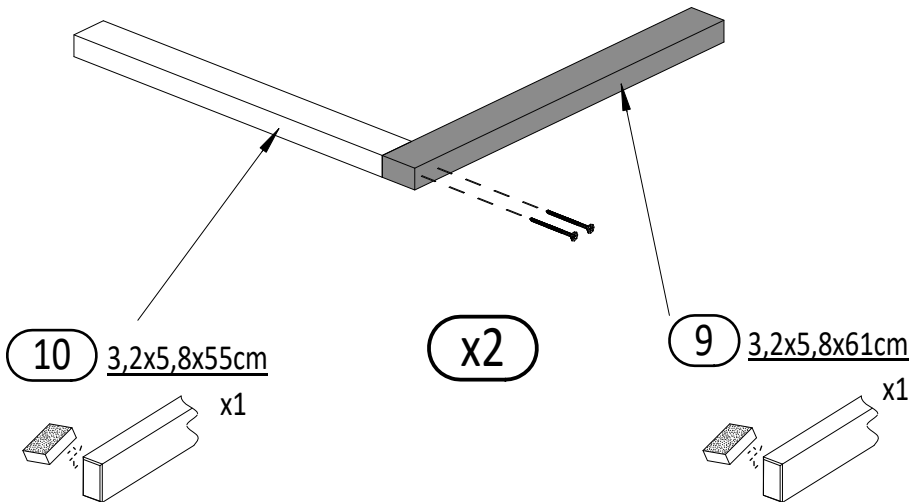
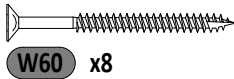
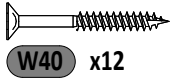
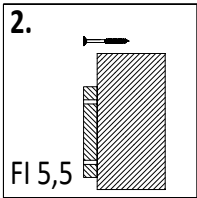
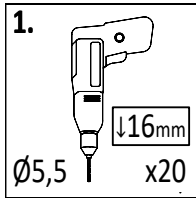
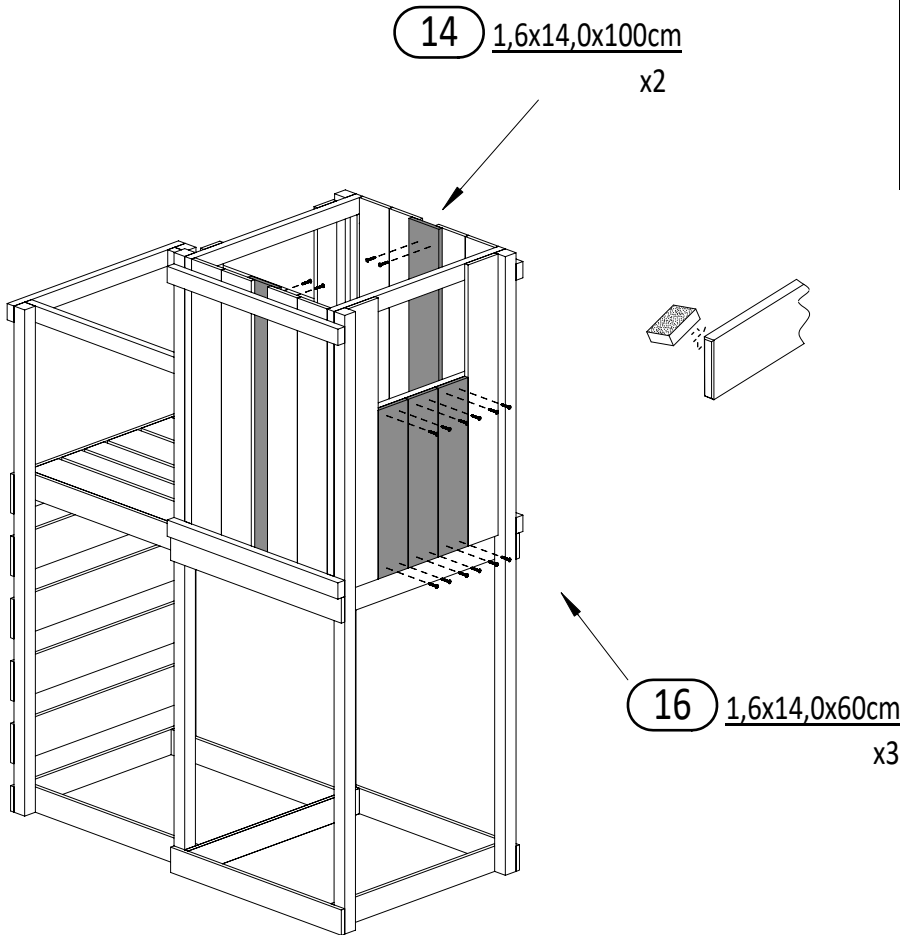

Zgodnie z normą PN-EN 71 stosuj zalecenia producenta odnośnie odległości oraz metody mocowania poszczególnych elementów
 In compliance with the standard PN-EN 71, apply guidelines of the producer in relation to distances and methods of fastening individual elements

17

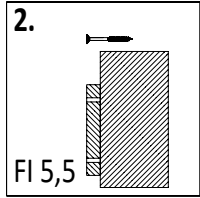
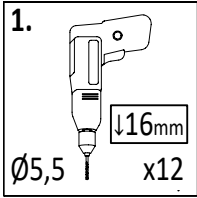

!!! x2

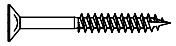
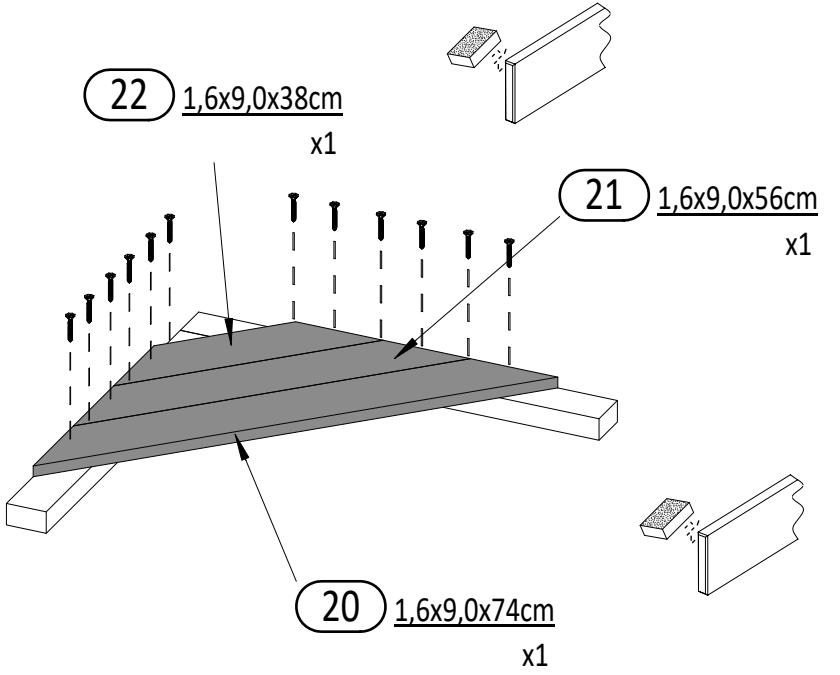

W40 x12 *2 = 24

18

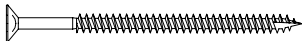
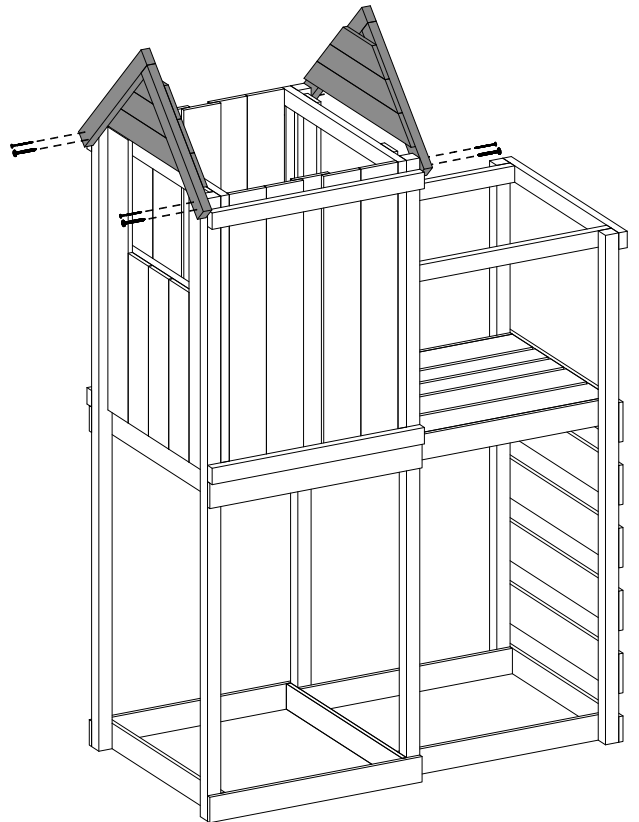
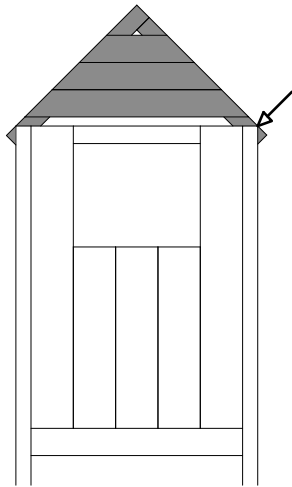
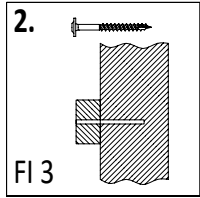
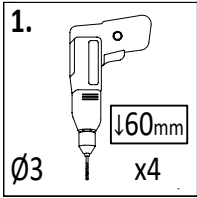

W80 x4



T60 x4

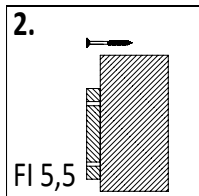
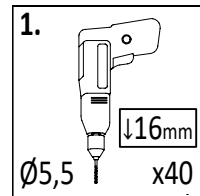
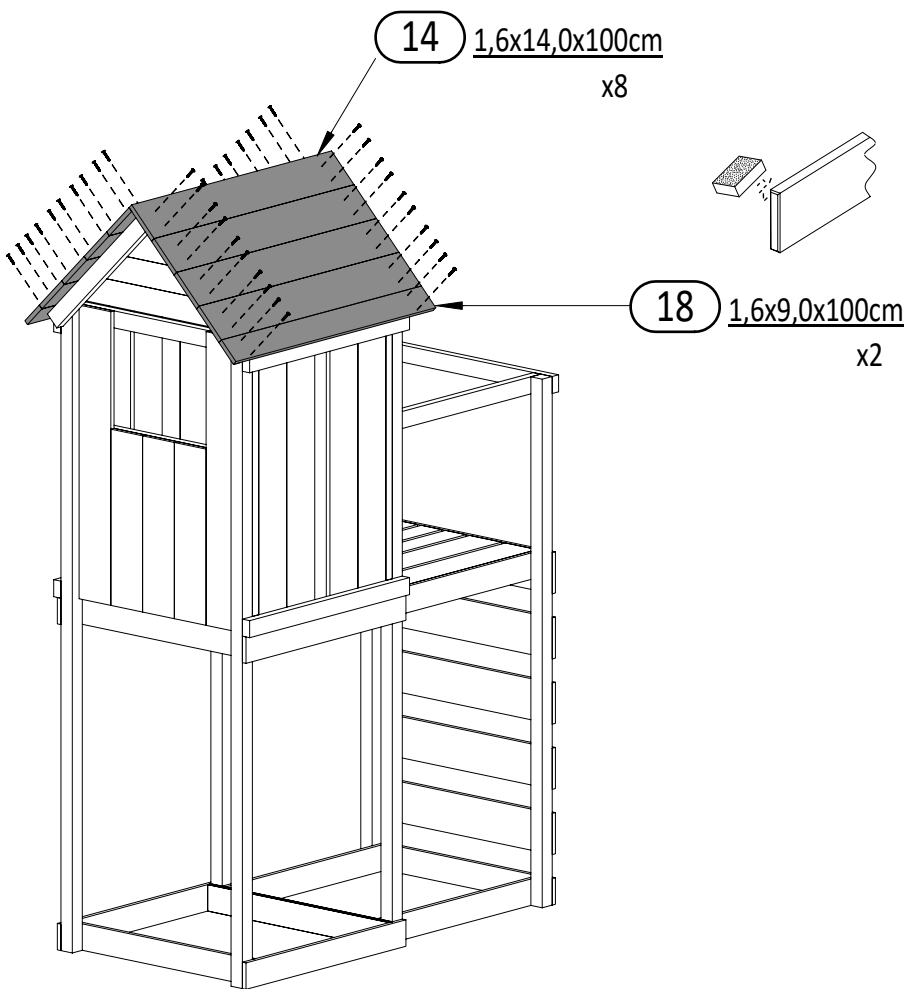

19

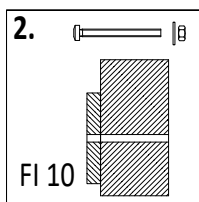
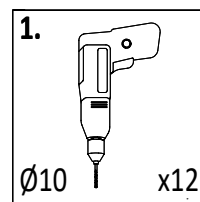
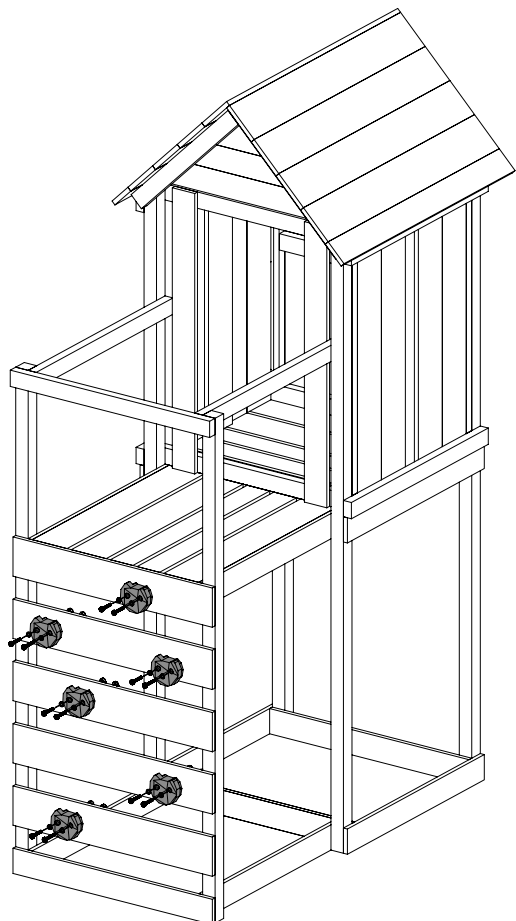
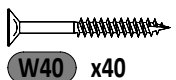
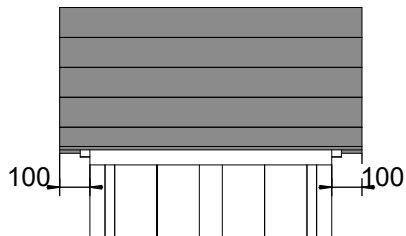

20

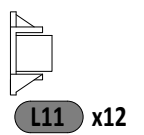
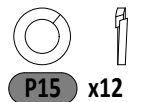
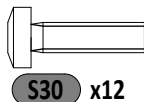
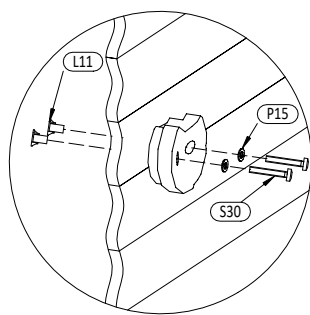
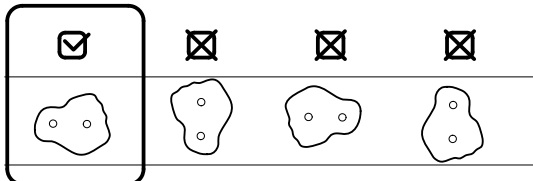

SW x6

Zgodnie z normą PN-EN 71 stosuj zalecenia producenta odnośnie odległości oraz metody mocowania poszczególnych elementów
 In compliance with the standard PN-EN 71, apply guidelines of the producer in relation to distances and methods of fastening individual elements

21

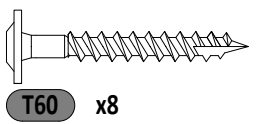
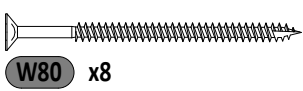
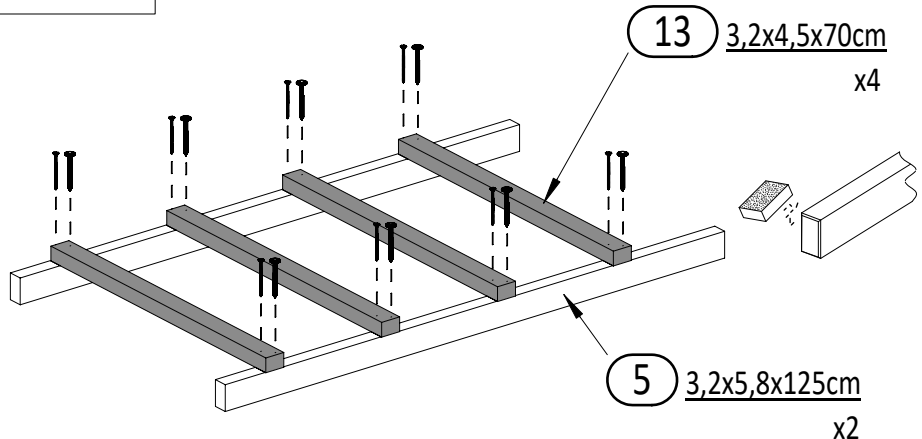
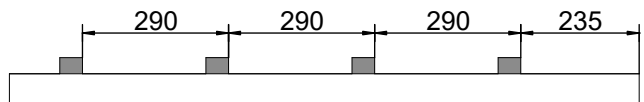
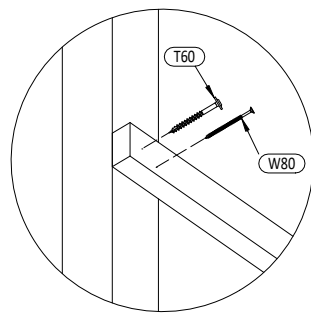
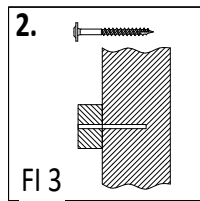
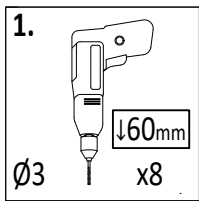

22

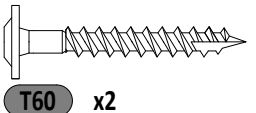
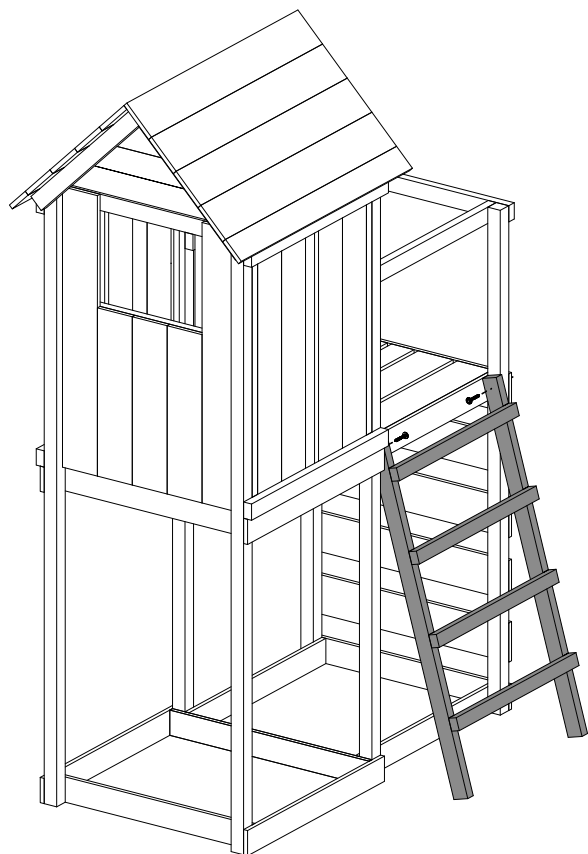
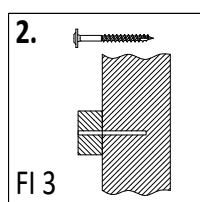
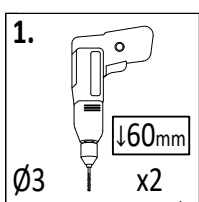

17 1,6x9,0x120cm x1

23a 1,6x9,0x30,0cm x1

2a 7,0x7,0x220cm x2

1a 9,0x9,0x220cm x1

1270

100

1. Ø5,5 x4 ↓80mm

2. FI 5,5 x1

90 90 90 90

T80 W80

W80 x8

T80 x4

1a 9,0x9,0x220cm x2

11a 3,2x5,8x32,4cm x1

12a 3,2x5,8x27,0cm x1

16

1. Ø5,5 x2 ↓80mm

2. FI 5,5 x1

W80

T80 W80

W80 x8

T80 x2

25

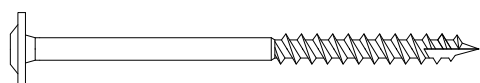
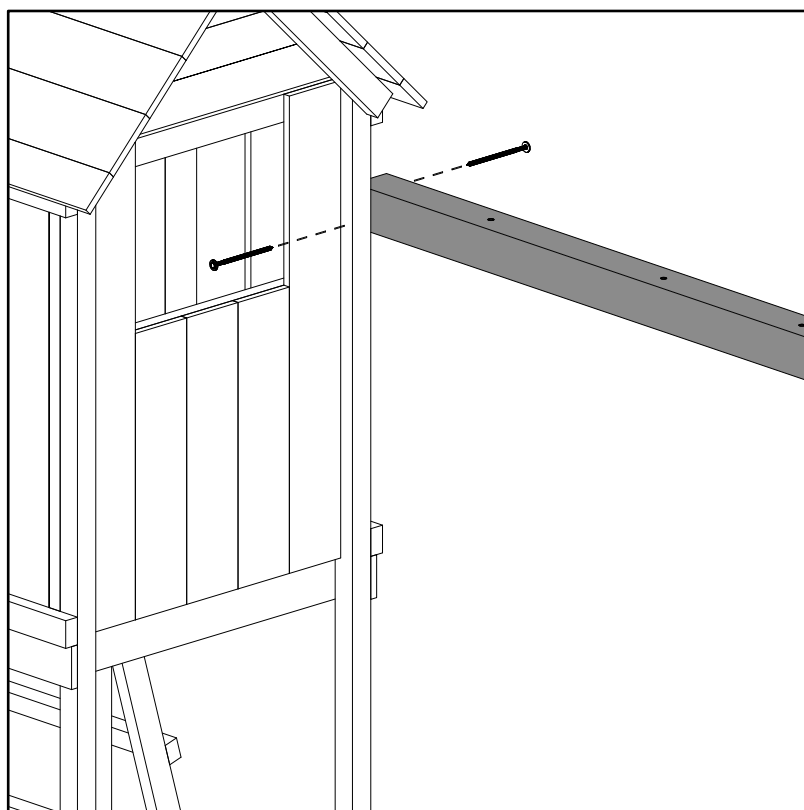
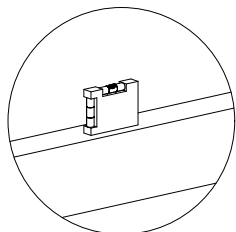
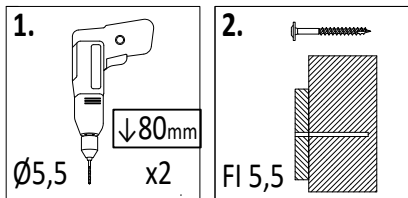

T120 x2

26

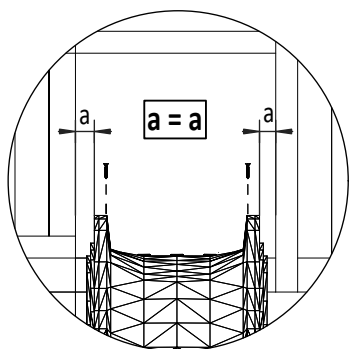

Z x1

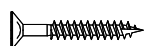
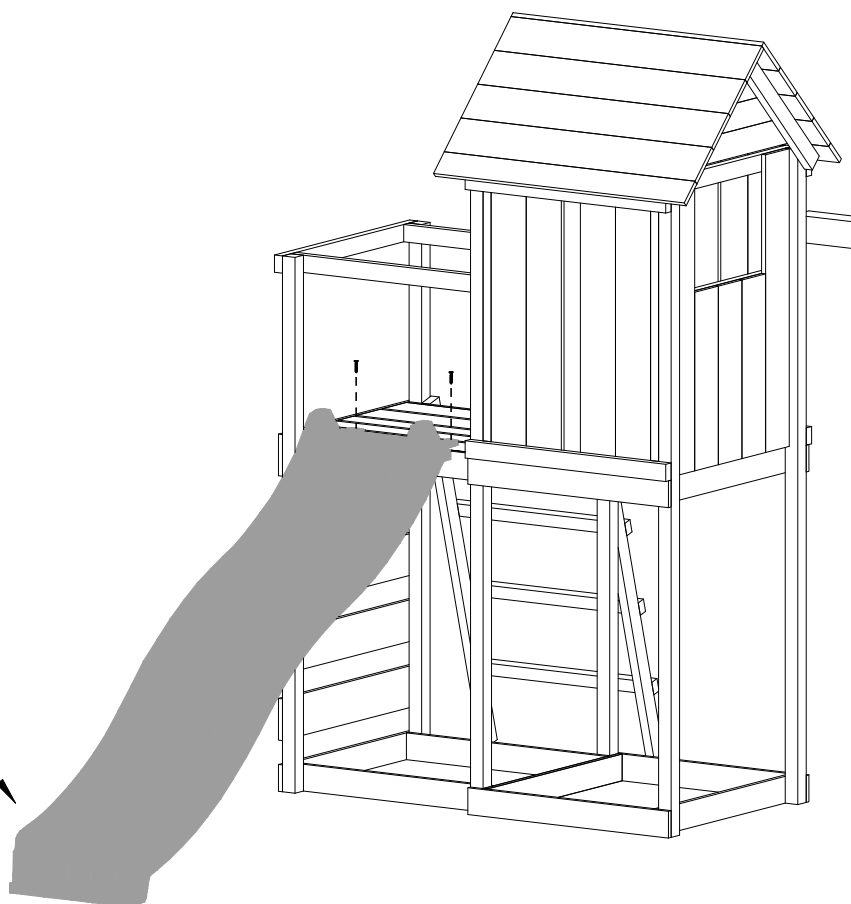

W30 x2

20 MaxPlay 3

Zgodne z normą PN-EN 71 stosuj zalecenia producenta odnośnie odległości oraz metody mocowania poszczególnych elementów
 In compliance with the standard PN-EN 71, apply guidelines of the producer in relation to distances and methods of fastening individual elements

UC

x2

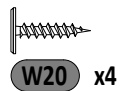
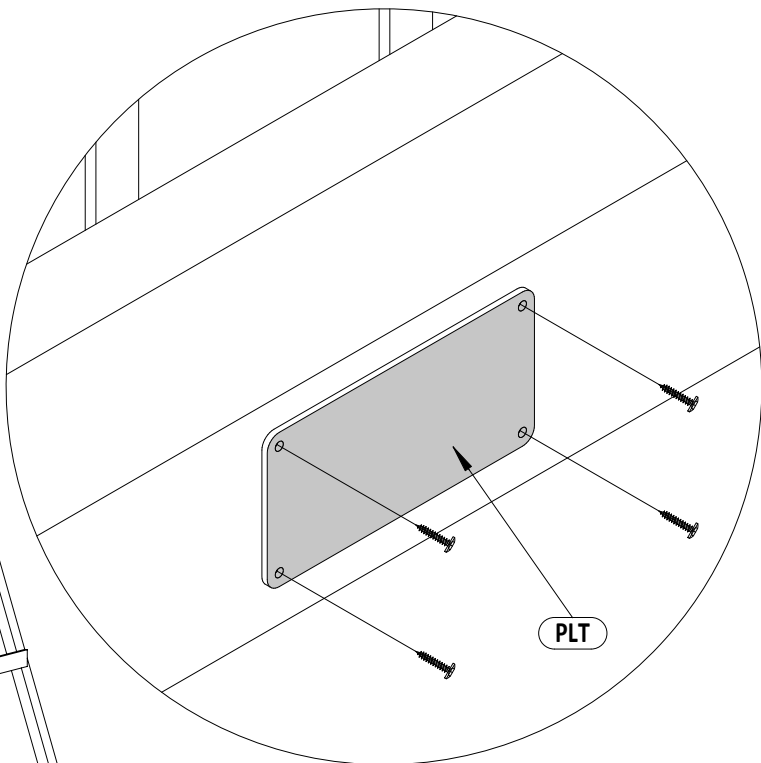
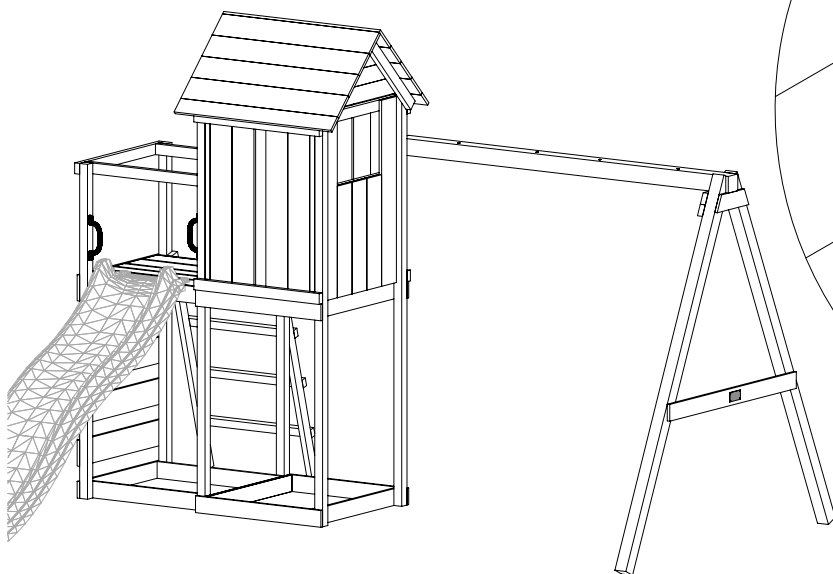
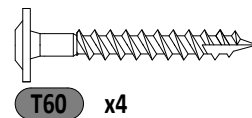
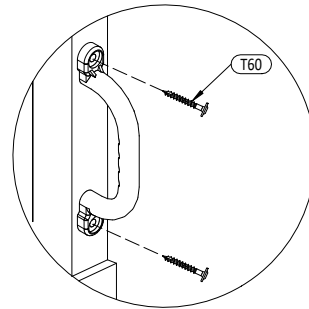
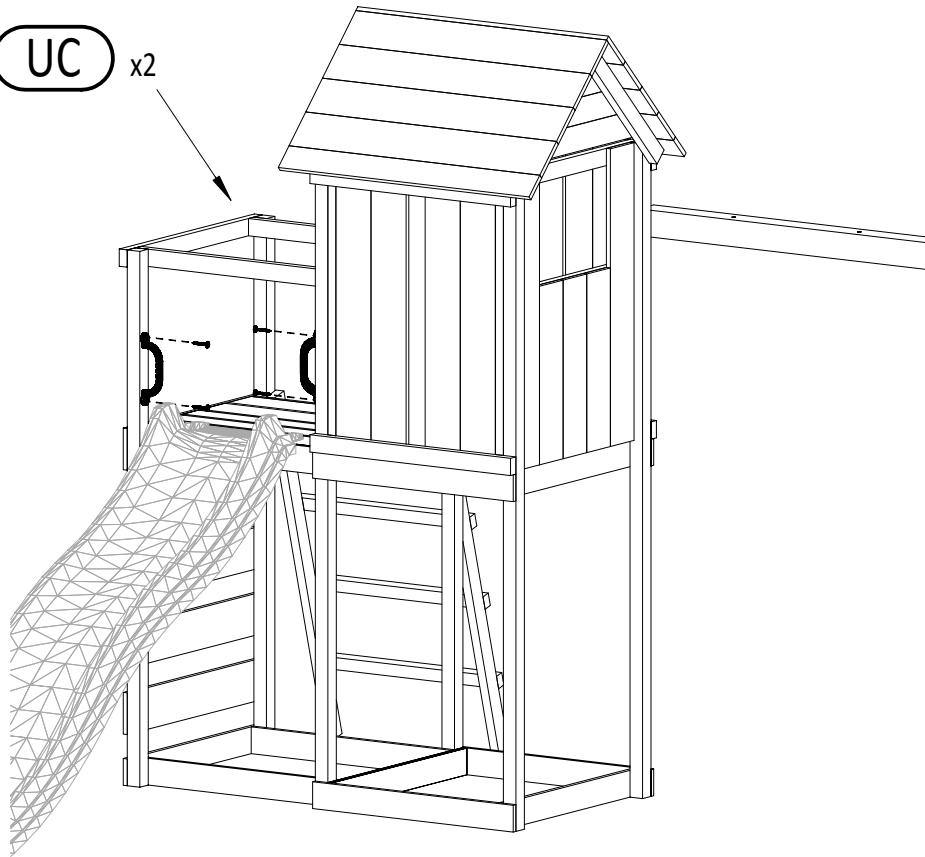

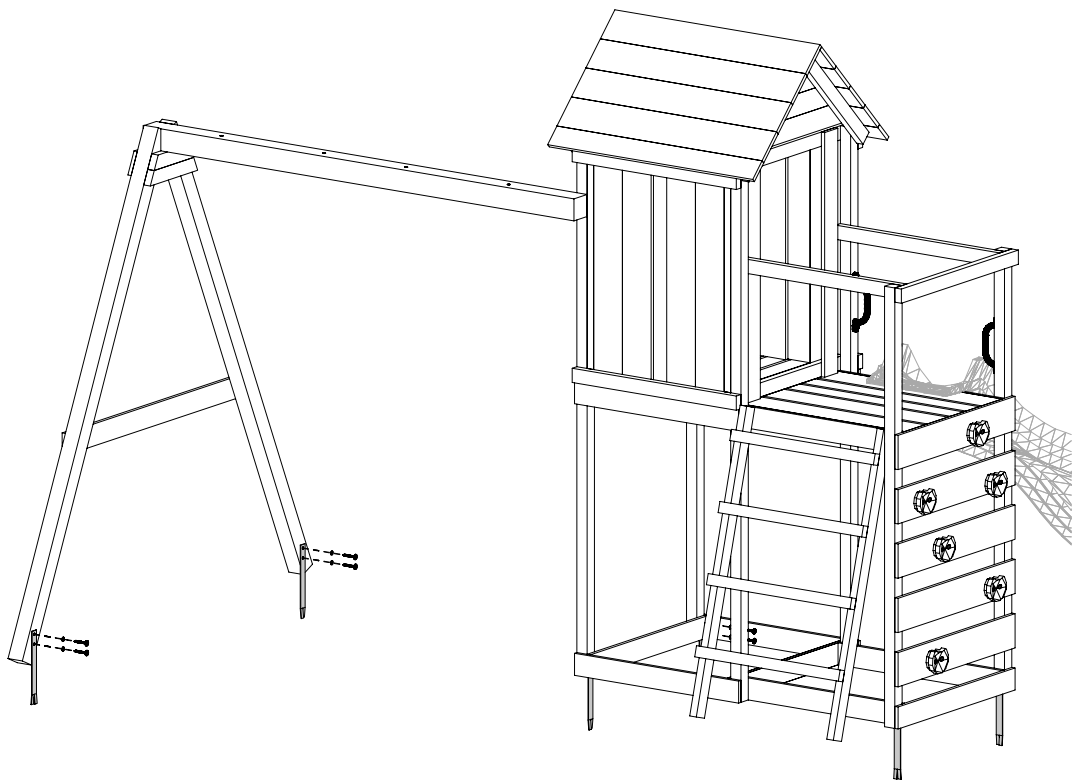

P17 x12

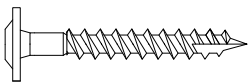

T60 x12

MG x6

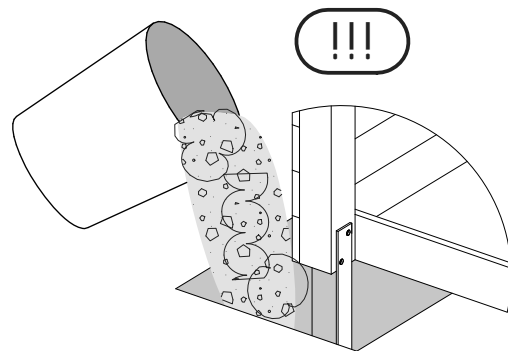
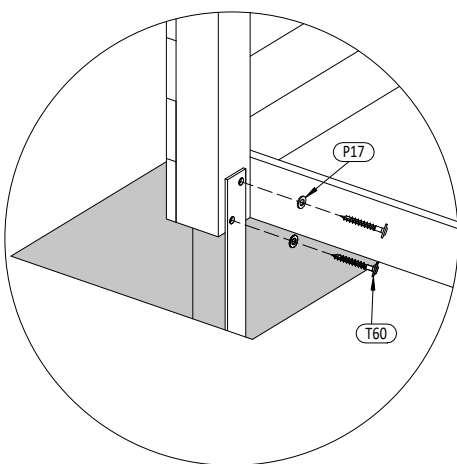

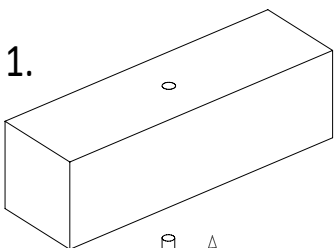
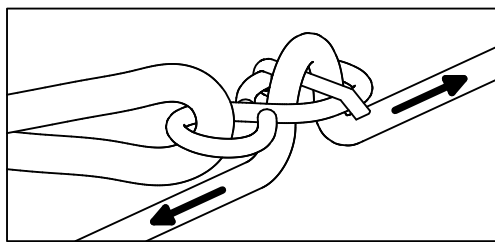
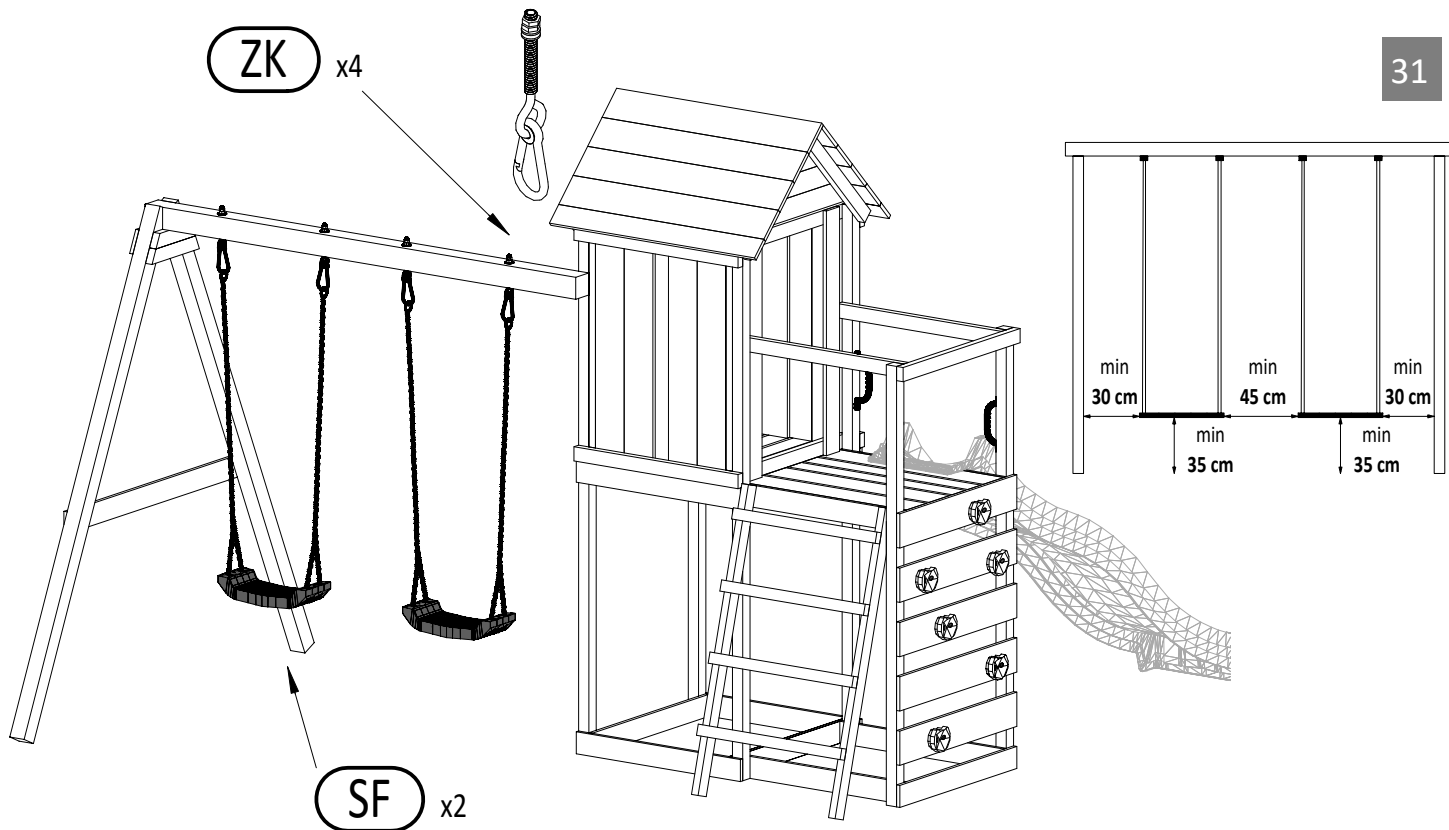

1.

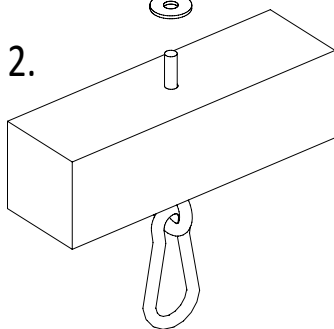

2.

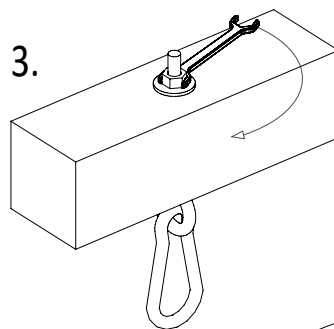

3.

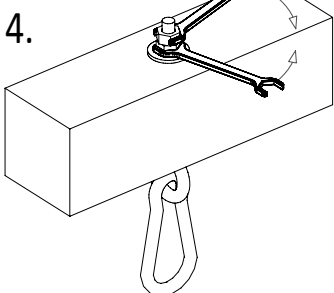
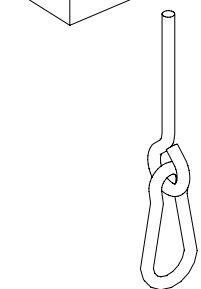

4.

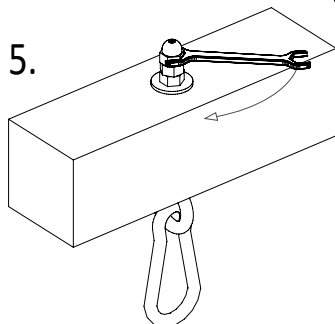
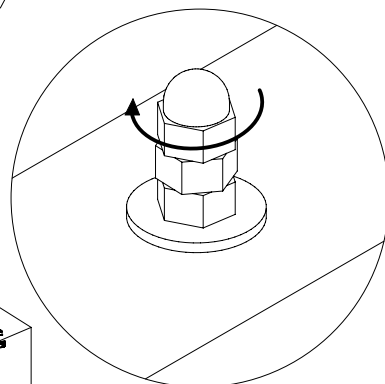
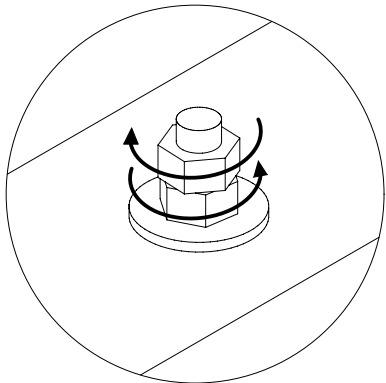

5.



M10 x4