

code: 10015

2640 x 3000 x 2255 mm

MONTAGEANLEITUNG
INSTALLATION INSTRUCTIONS

INSTRUCTIONS D'INSTALLATION
INSTRUKCJA MONTAŻU

v 1

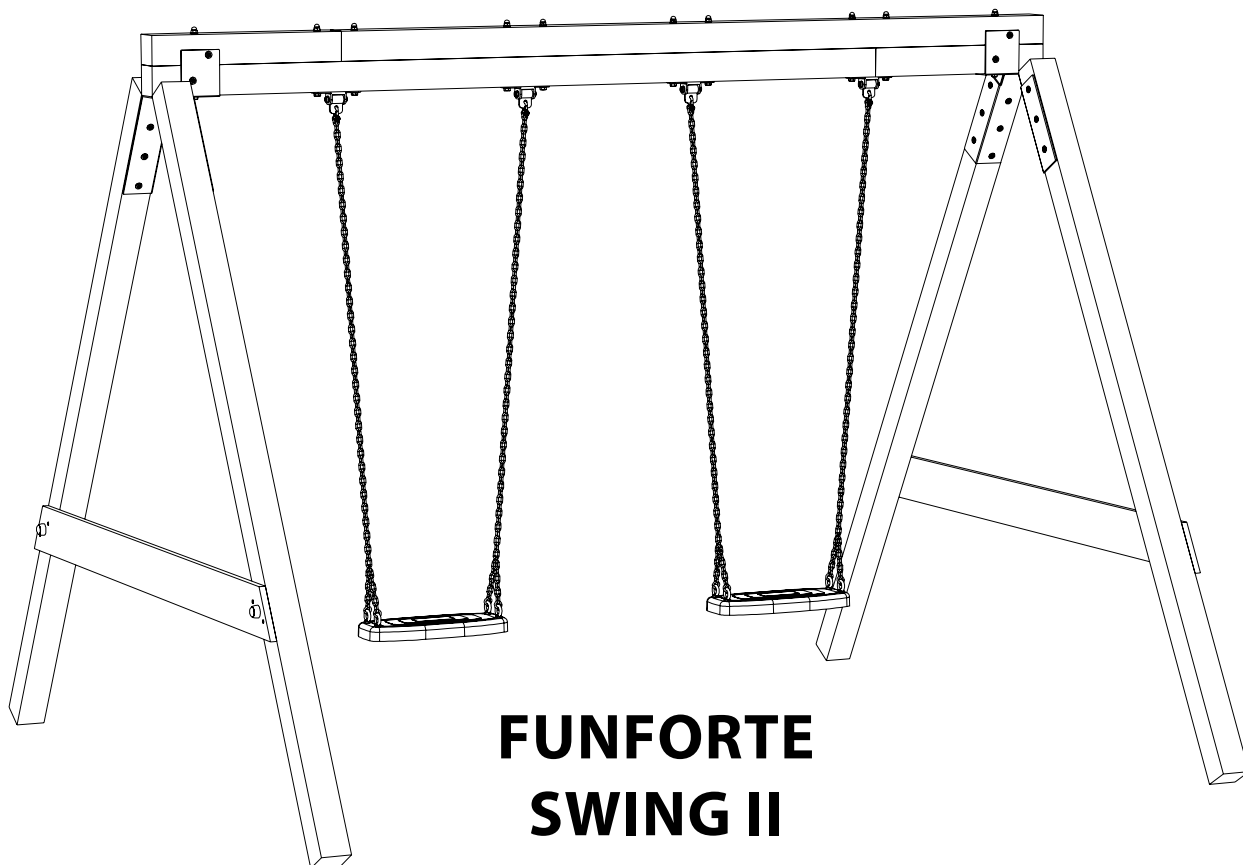

**FUNFORTE
SWING II**

PN-EN - 1176



ACHTUNG!

- Ausschließlich für die Verwendung im Freien
- Nicht geeignet für Kinder unter 3 Jahren
- Stolper- und / oder Sturzgefahr
- Höchstgewicht pro Einzelkind beträgt 50 kg
- Der Aufenthalt auf diesem Spielturm ist max.: 2 Kindern gleichzeitig erlaubt

AVERTISSEMENT!

- Uniquement pour usage externe
- Ne convient pas aux enfants de moins de 3 ans
- Risque de chute et/ou de choc
- Le poids maximum de l'utilisateur est de 50 kg
- Nombre maximum d'utilisateurs pouvant rester sur l'aire de jeux en même temps: 2

WARNING!

- Dedicated for external use only
- Not suitable for children under 3 years old
- Risk of falling down and/or hitting
- Maximum user weight is up to 50 kg
- Maximum number of users staying on the playground at the same time: 2

UWAGA!

- Wyrób przeznaczony do użytku na zewnątrz
- Nie przeznaczony dla dzieci poniżej 3 roku życia
- Niebezpieczeństwo upadku i/lub uderzenia
- Maksymalna waga użytkownika to 50 kg
- Maksymalna liczba użytkowników przebywających na placu jednocześnie: 2



Garantiezeit - 2 Jahre ab Kaufdatum

Warranty period - 2 years from purchase date

Période de garantie - 2 ans à compter de la date d'achat

Okres gwarancji - 2 lata od momentu zakupu towaru

DEUTSCH



Es sollen die Empfehlungen des Herstellers in Bezug auf die Entfernung u. Befestigungsmethode einzelner Elemente gem. der Norm PN-EN 1176 beachtet werden.

Die Montageanleitung soll für ihre zukünftige Verwendung aufbewahrt werden.

ENGLISH



In compliance with the standard PN-EN 1176, apply guidelines of the producer in relation to distances and methods of fastening individual elements

Please keep this manual for future reference

FRANÇAIS



Conformément a la norme PN-EN 1176 il convient de respecter les consignes du fabricant relatives aux distances entre les éléments de l'installation ainsi qu'a la façon de leur fixation.

Veillez conserver les instructions de montage pour référence future

POLSKI



Zgodne z normą PN-EN 1176 stosuj zalecenia producenta odnośnie odległości oraz metody mocowania poszczególnych elementów

Prosimy o zachowanie instrukcji montażu na przyszłość

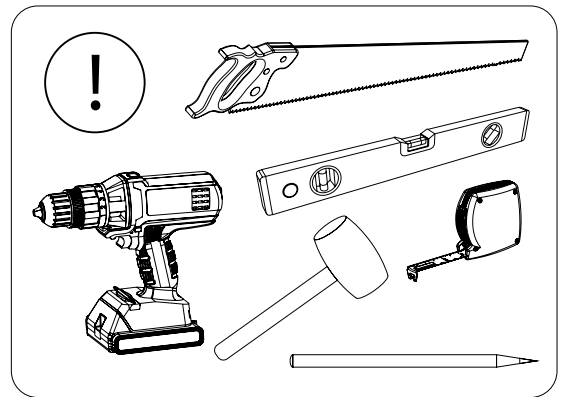
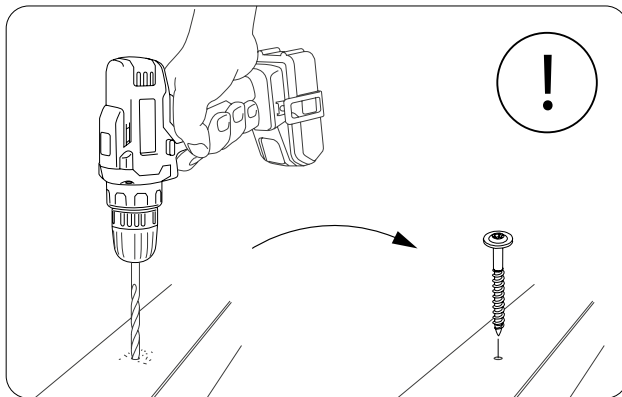
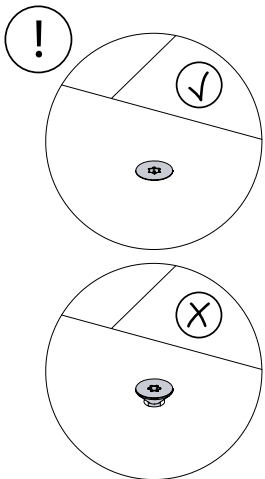
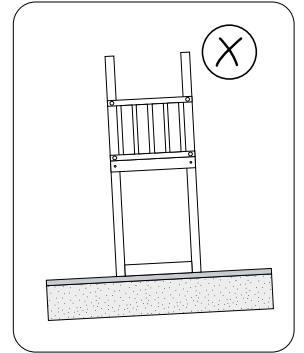
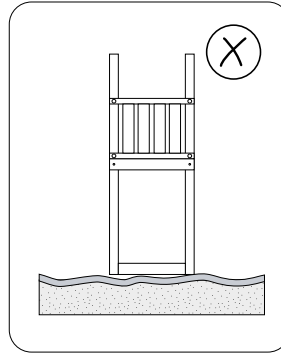
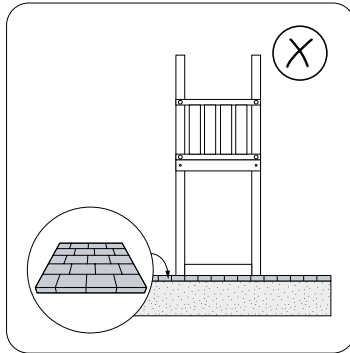
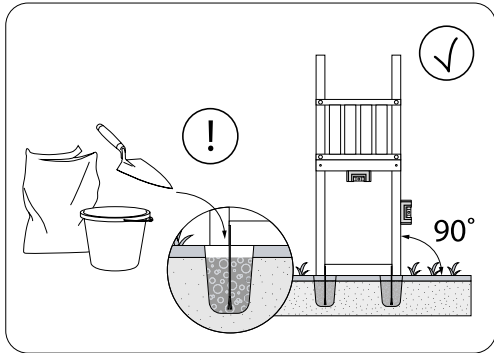
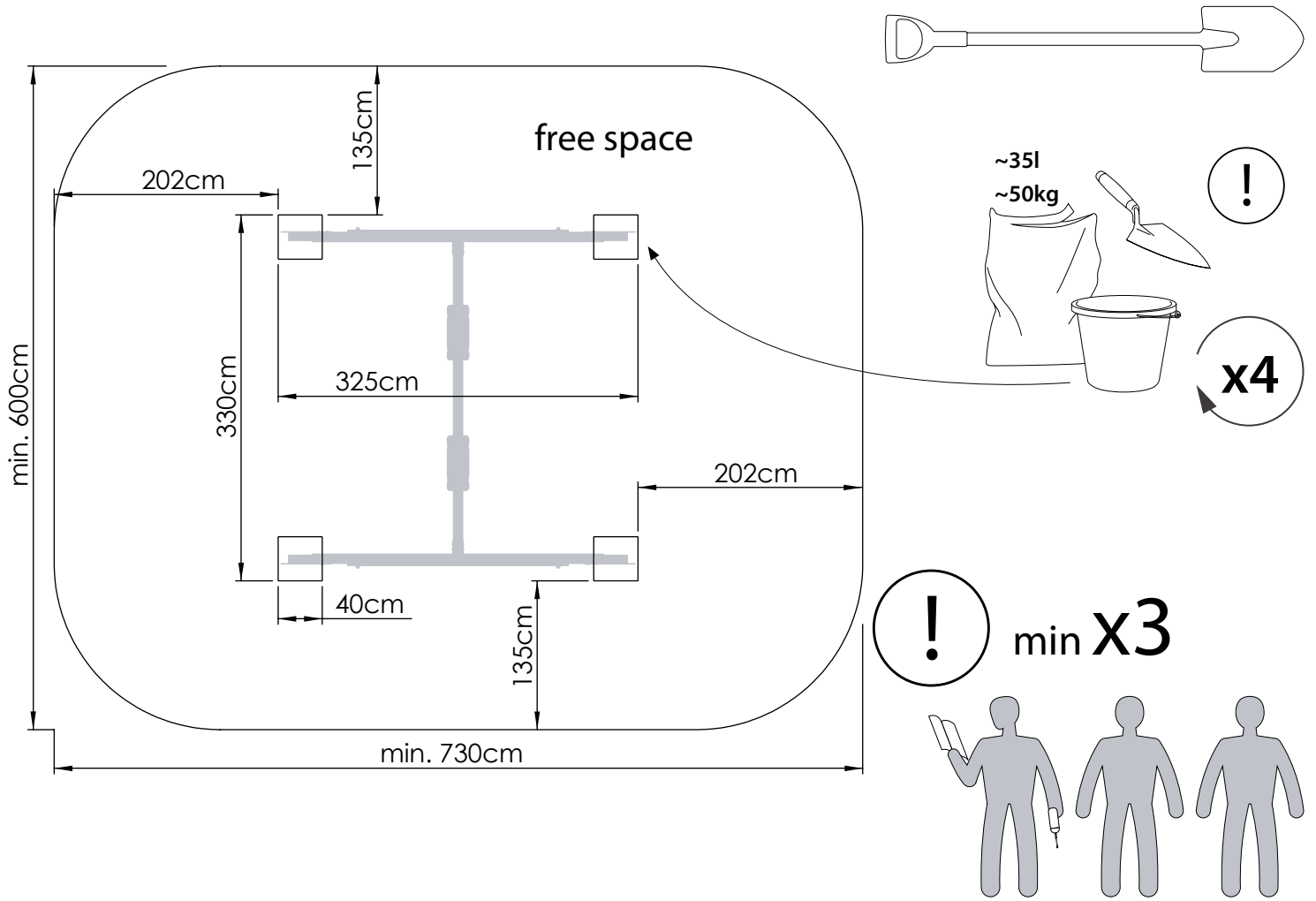

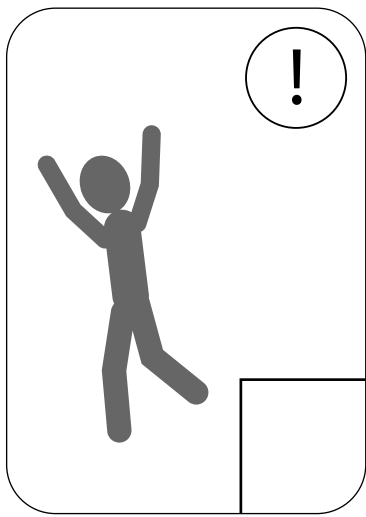

H = free height of fall

H = min **1,25m**

impact area = **7,3 x 2,82m**

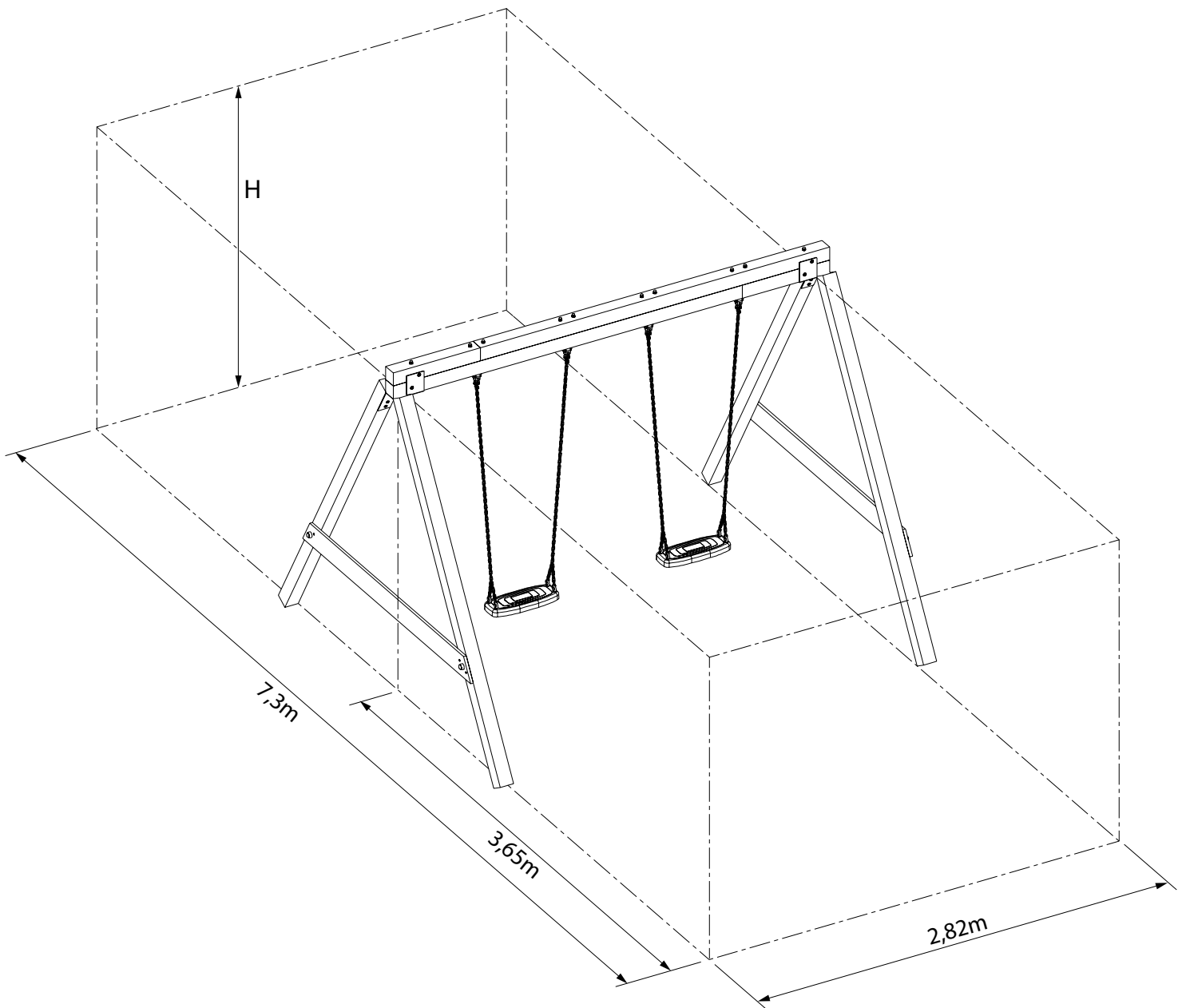

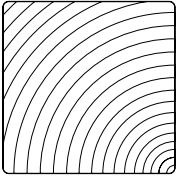

90 x 90

- x4 10200 ① 2400mm
- x2 10026 ② 2400mm
- x2 10028 ③ 600mm

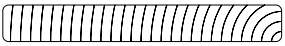

19 x 145

- x2 10252 ④ 2000mm

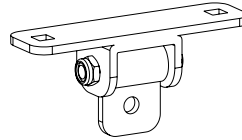
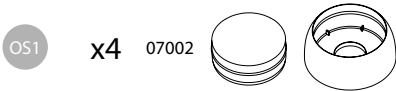
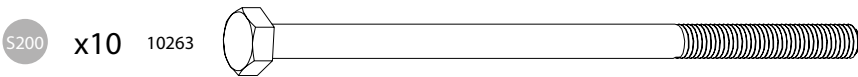
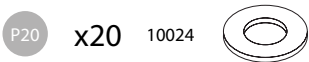
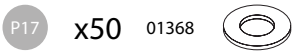
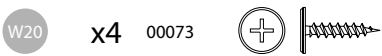
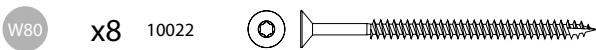
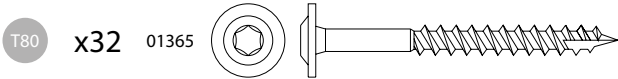
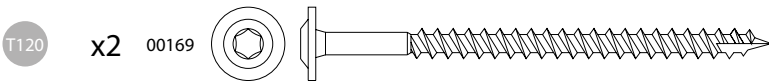

10025
⑤ x4



10264
⑥ x10

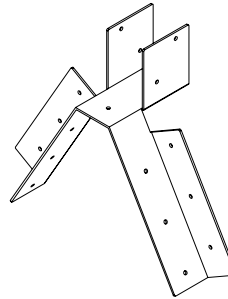

10253
⑦ x2

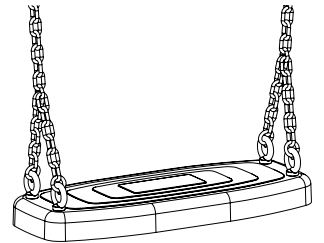

10195 10266
⑧ x2

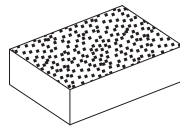
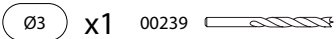

04657
x1



10265
⑨ x1

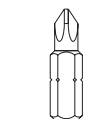

00068
PH3 x1

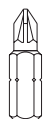

00241
PZ2 x1



00190
TX25 x1



00316
TX30 x1

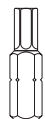

00242
TX40 x1

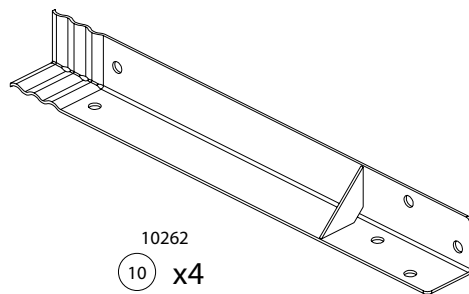

10262
⑩ x4

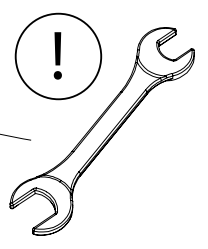
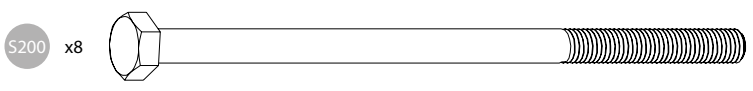
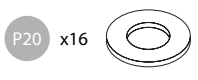
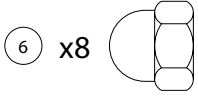
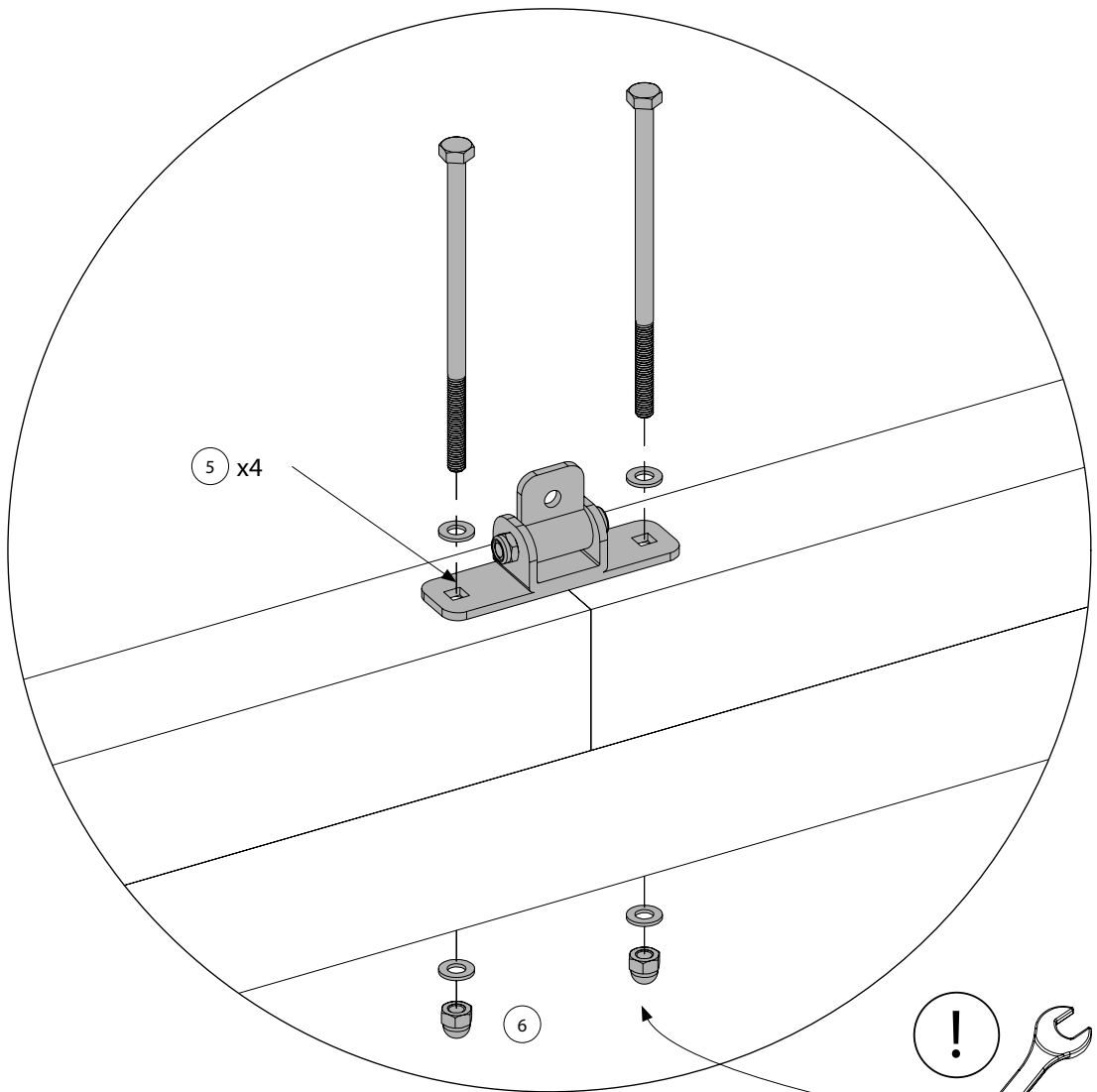
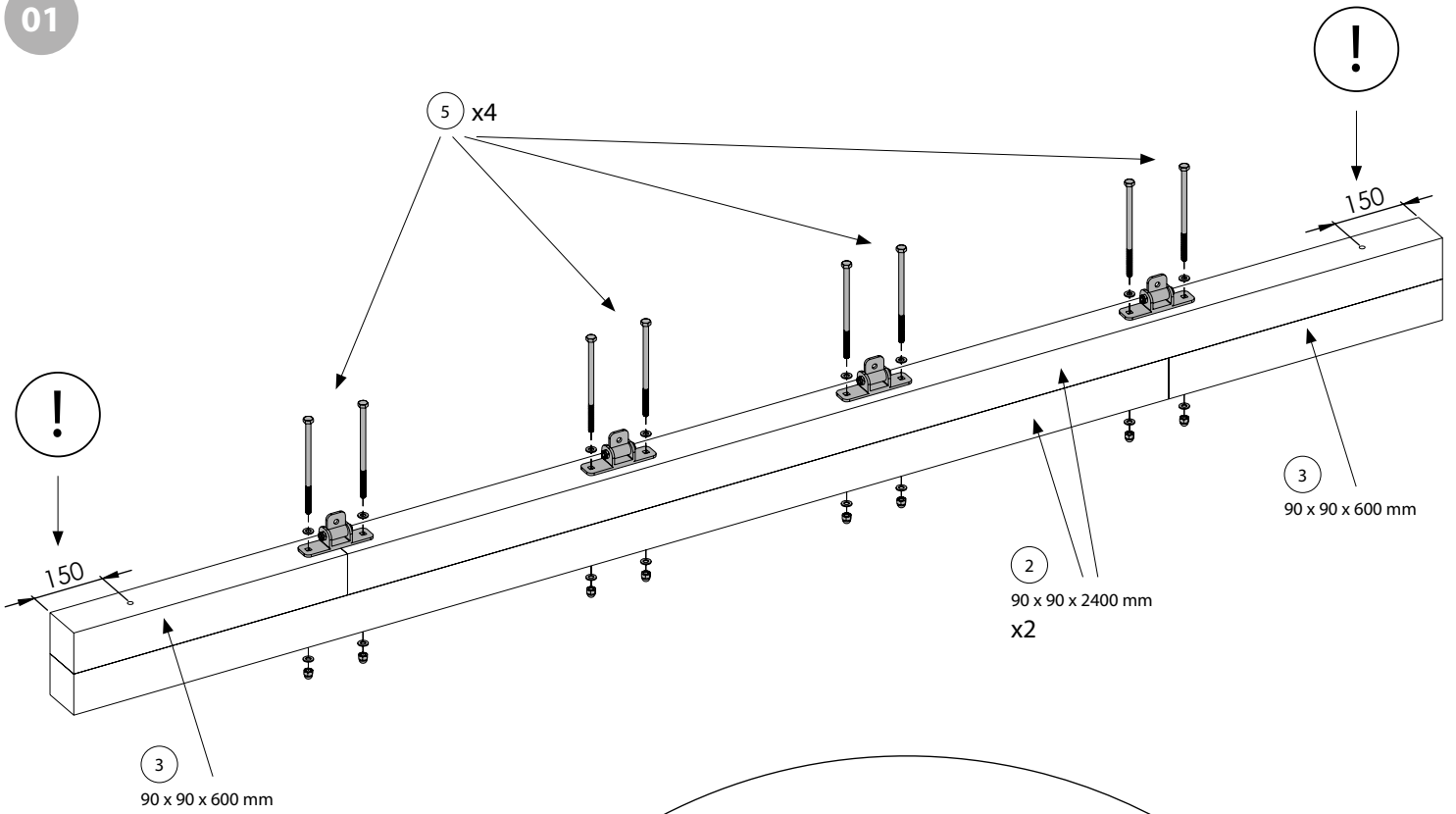

02

Ø5,5 x10

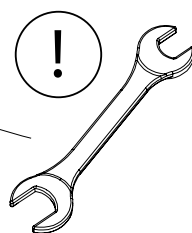
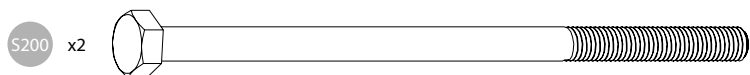
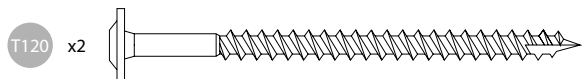
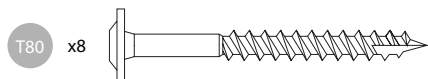
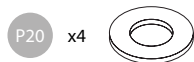
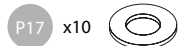
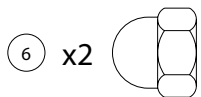
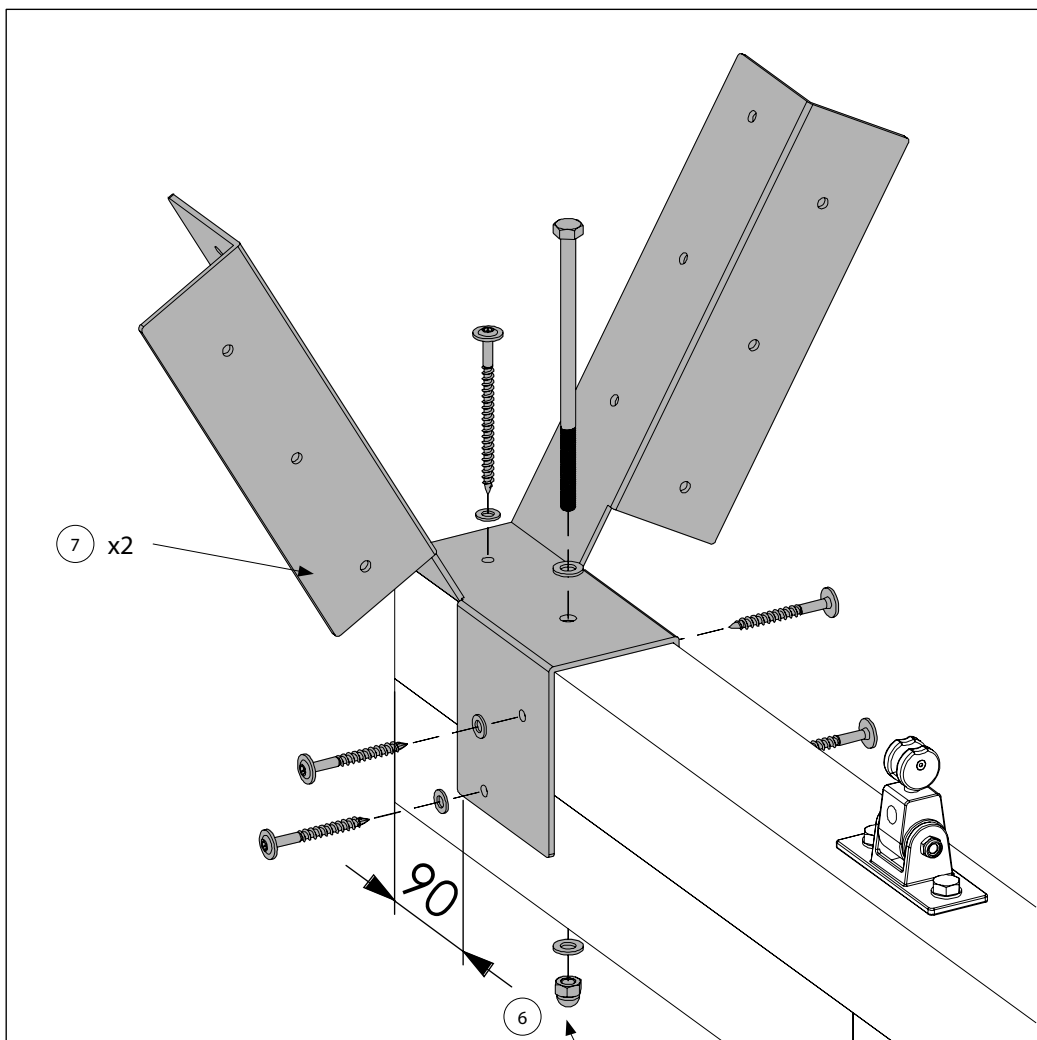
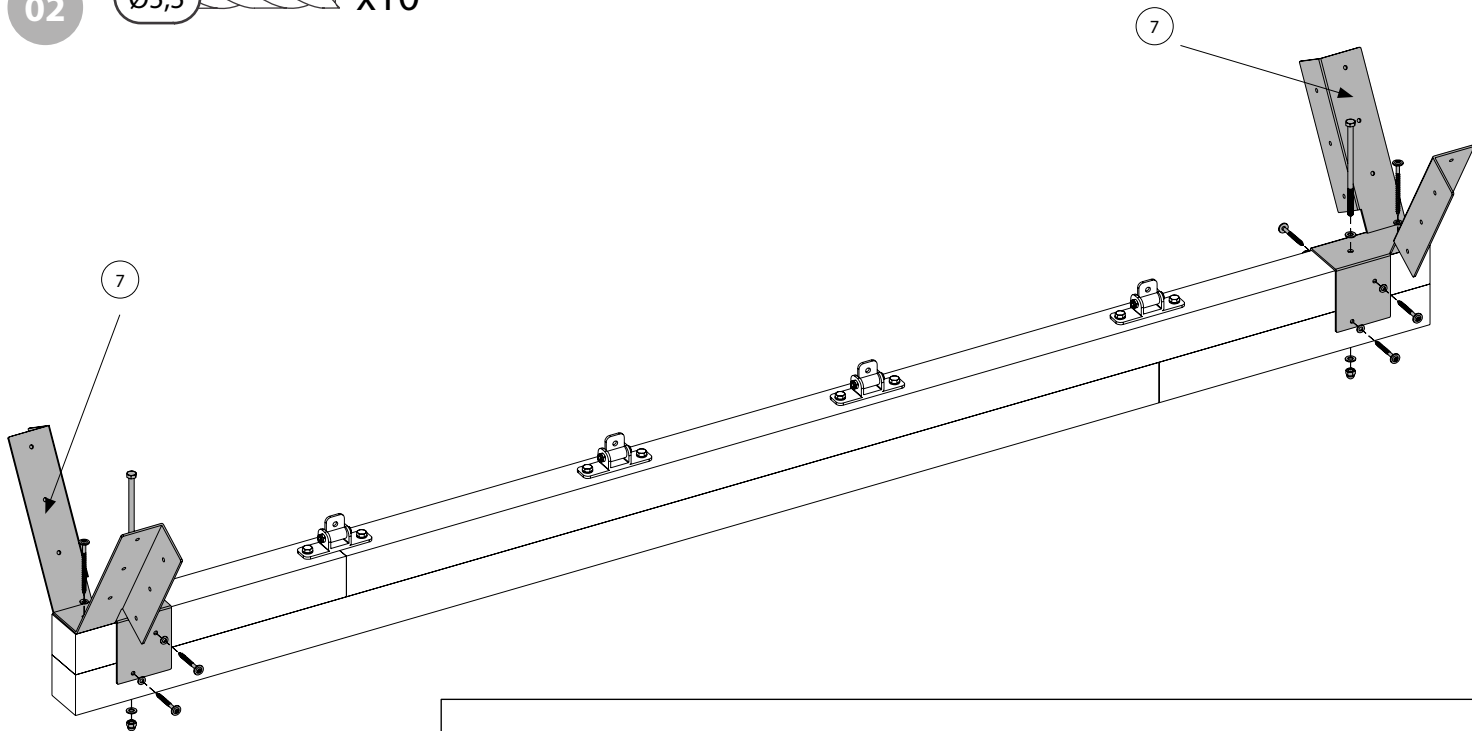

03

Ø5,5 x24

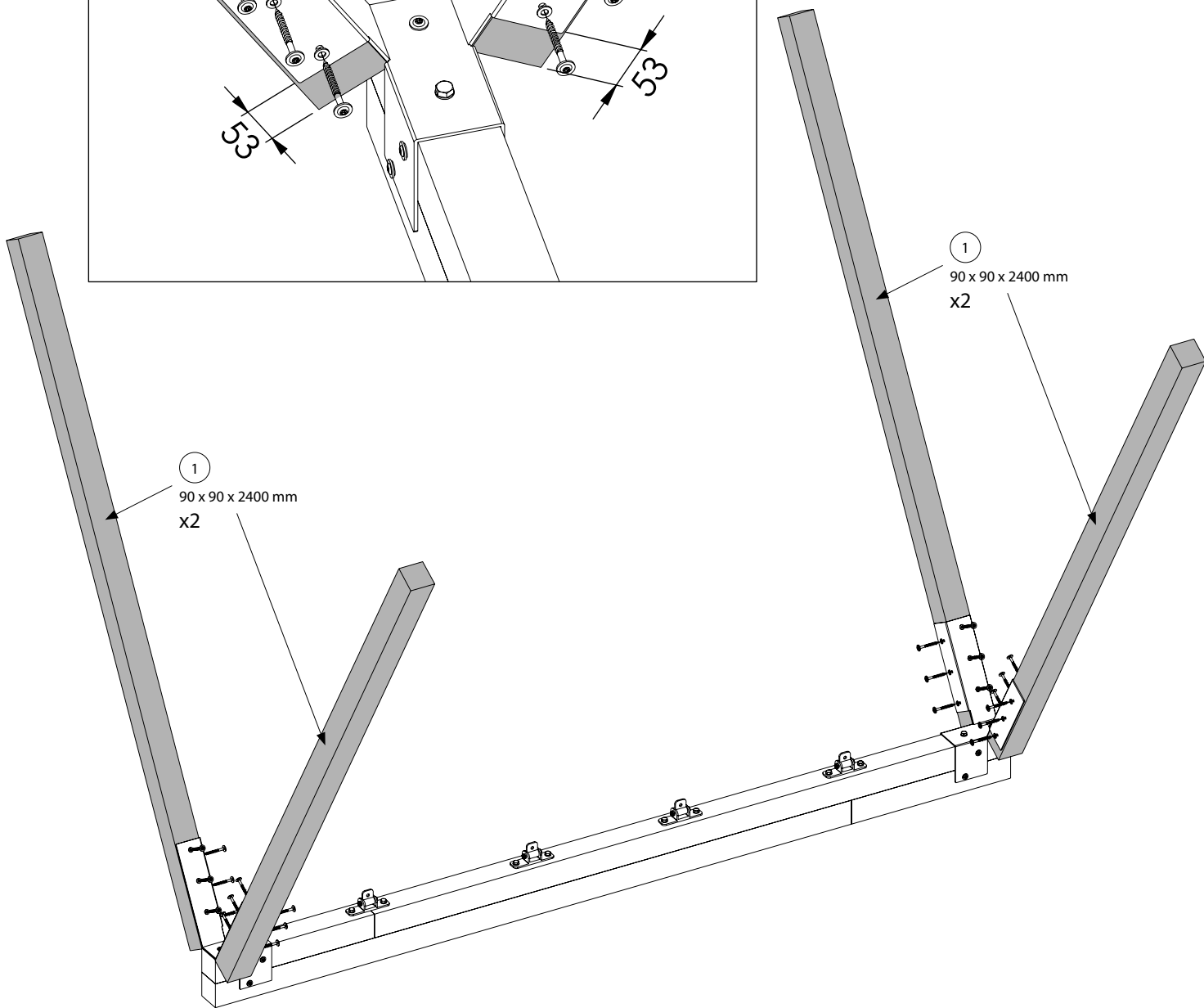
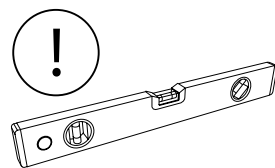
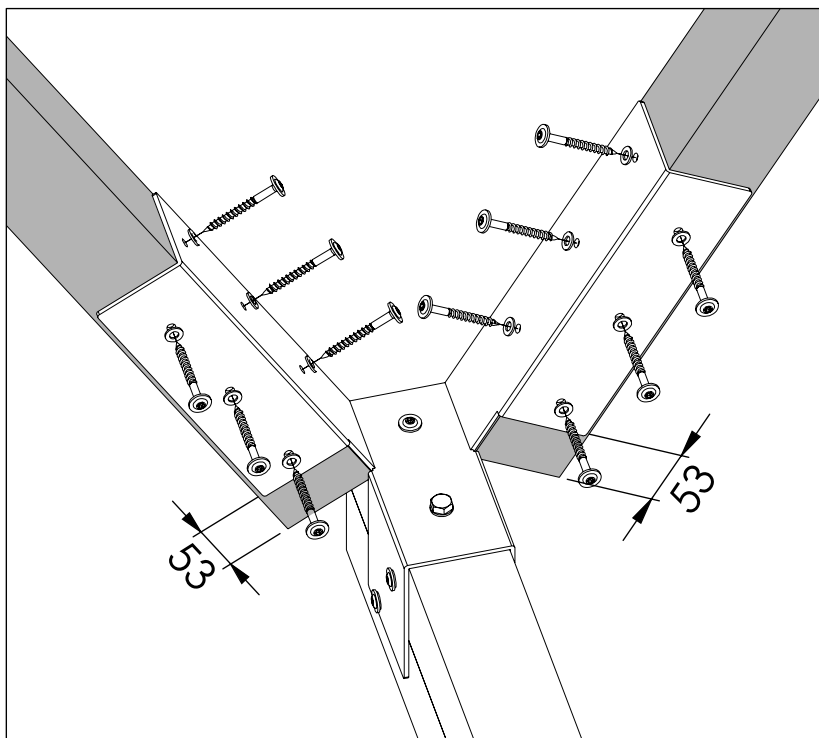

P17 x24



T80 x24



04

Ø3 x8

Ø5,5 x4

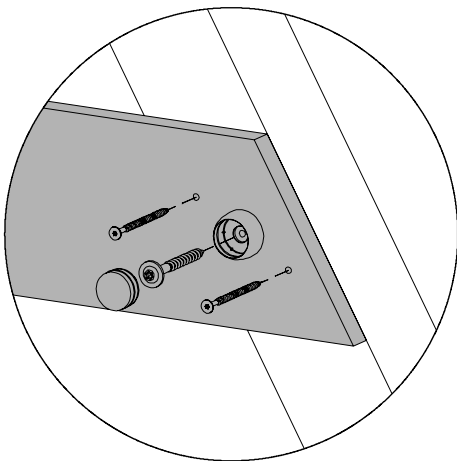
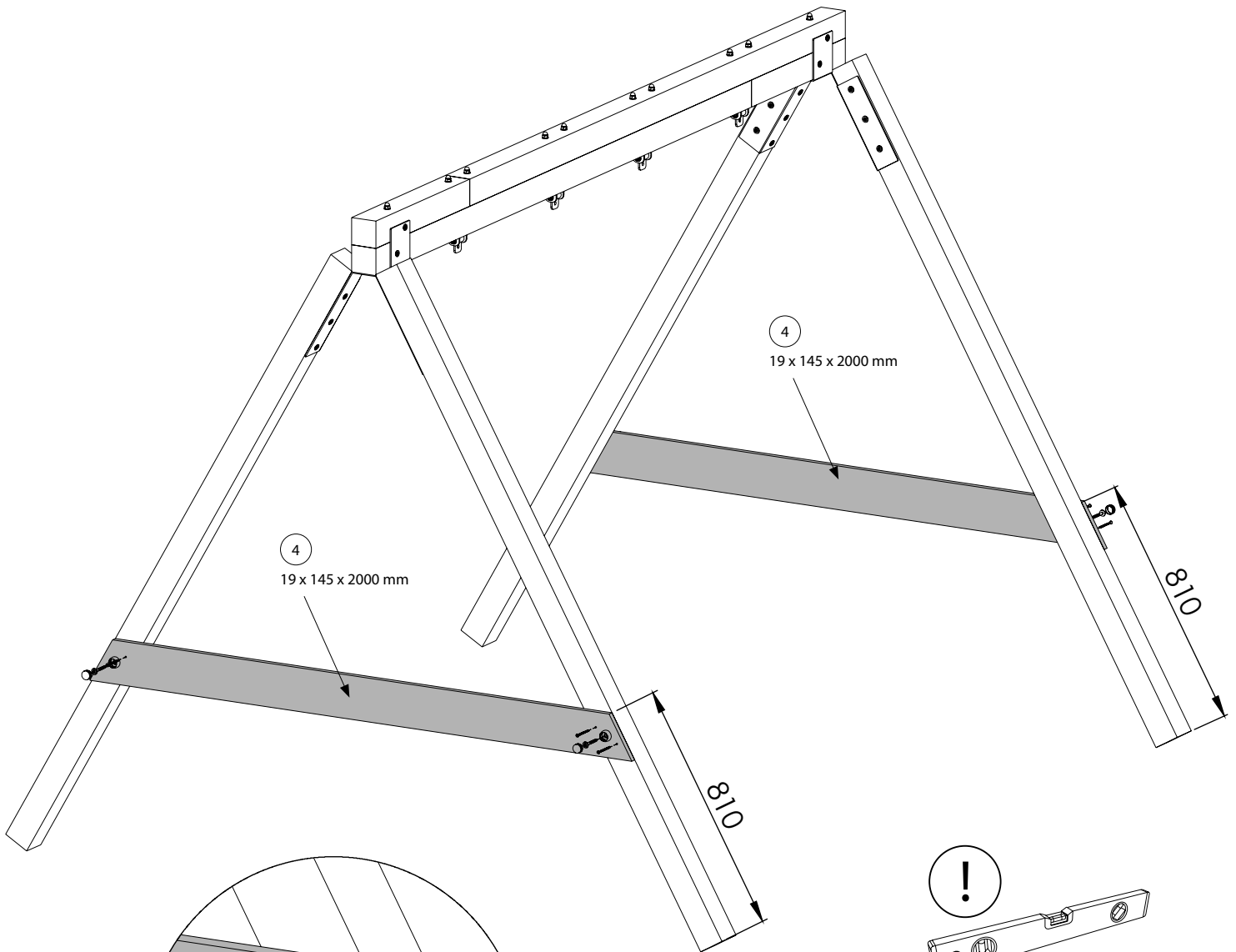

OS1 x4



W80 x8



T80 x4

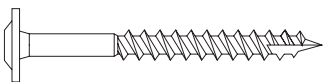

05

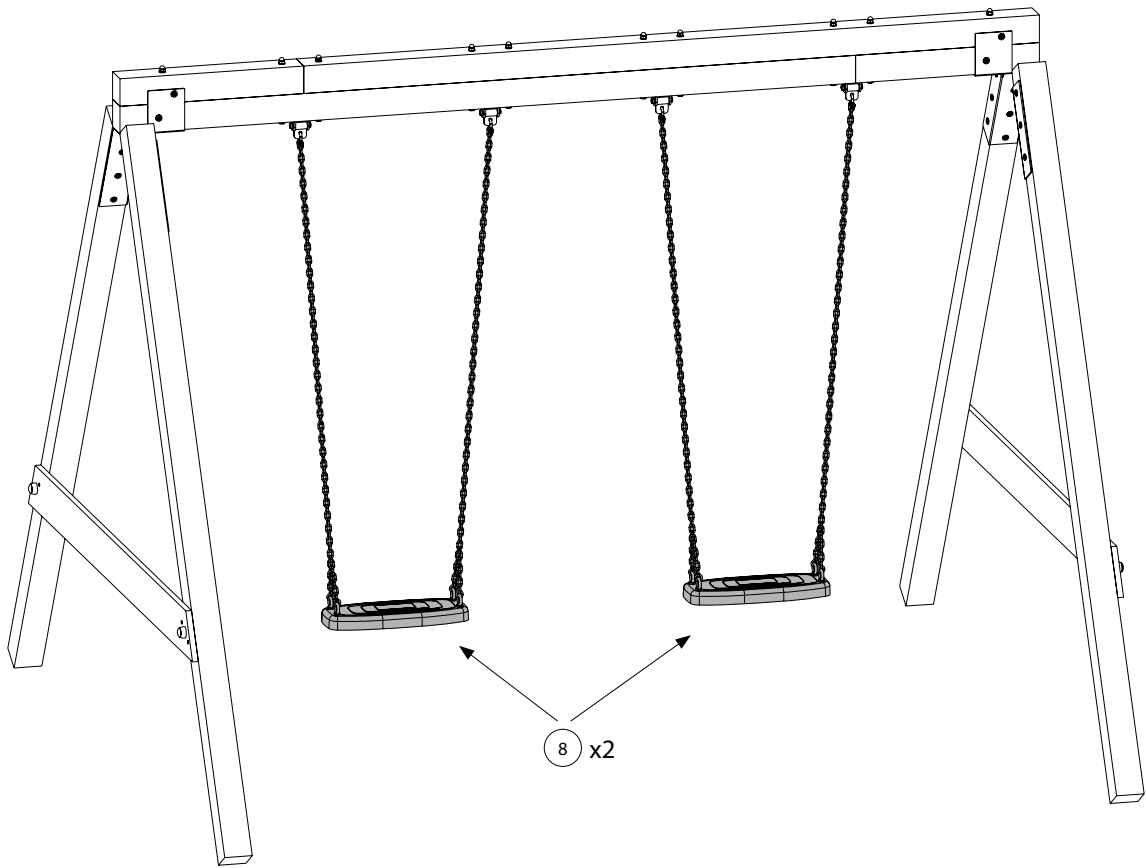

06

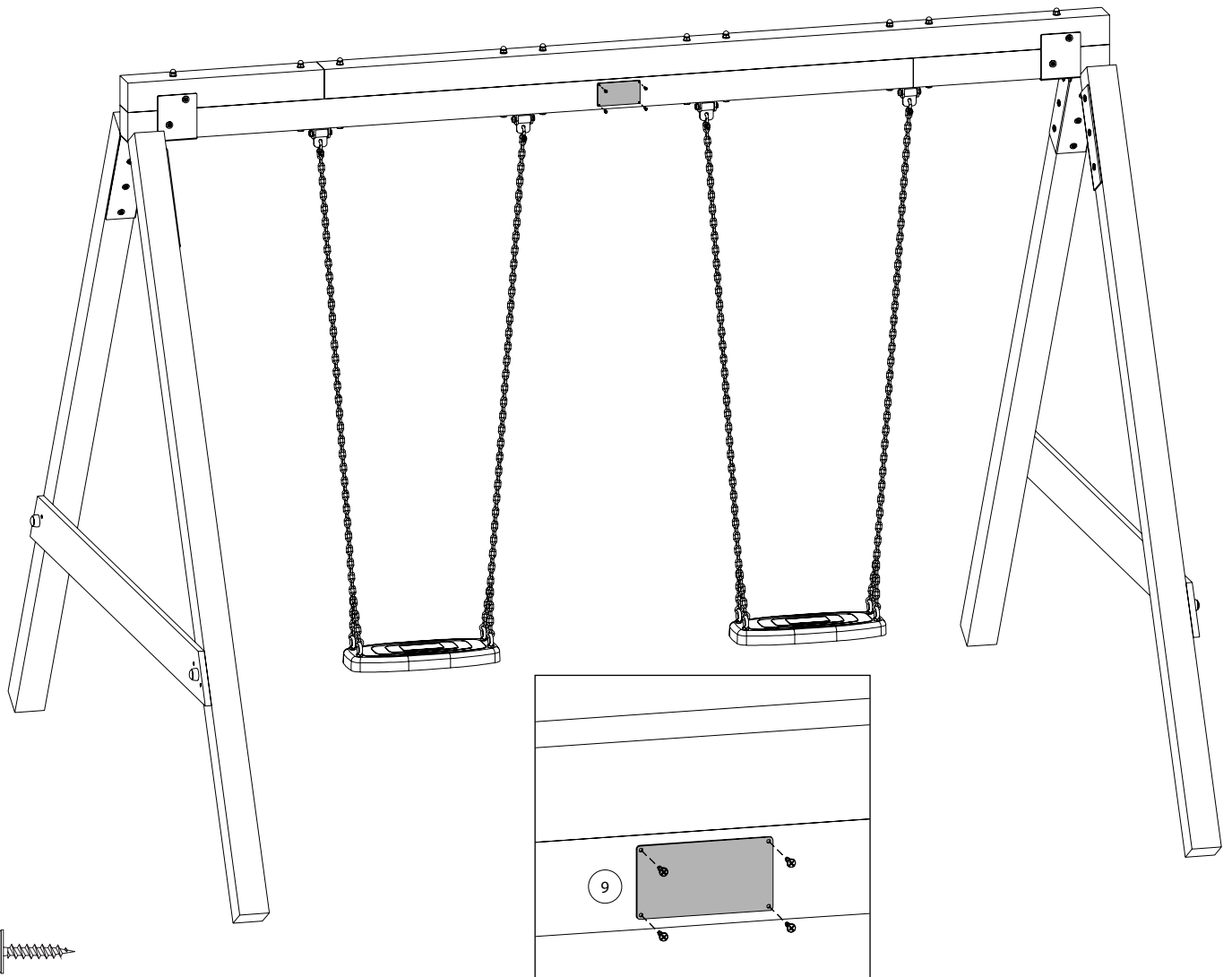

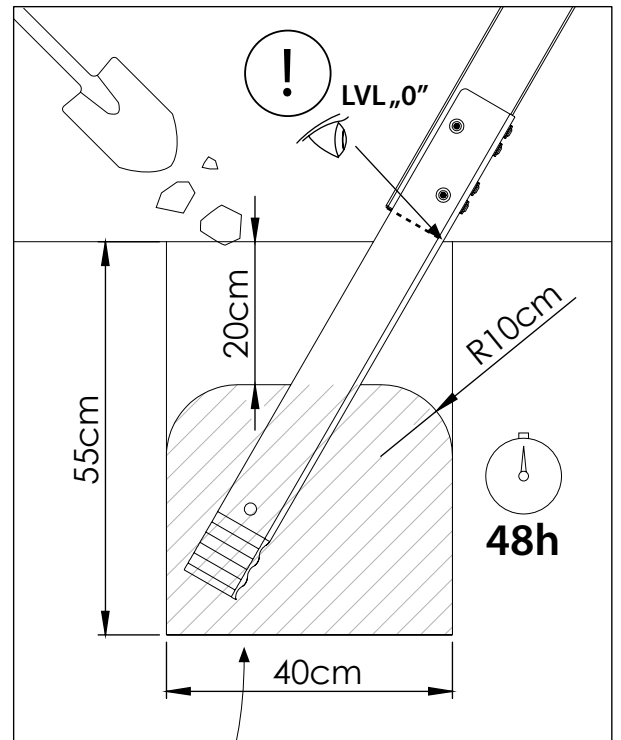
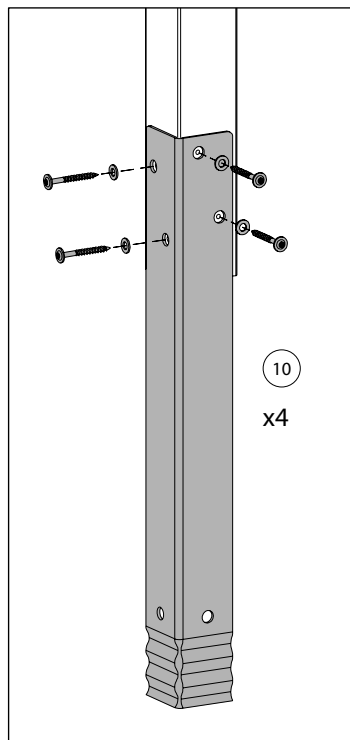
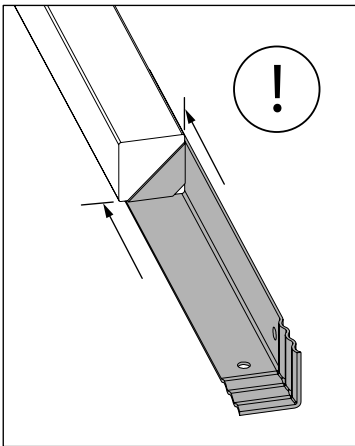
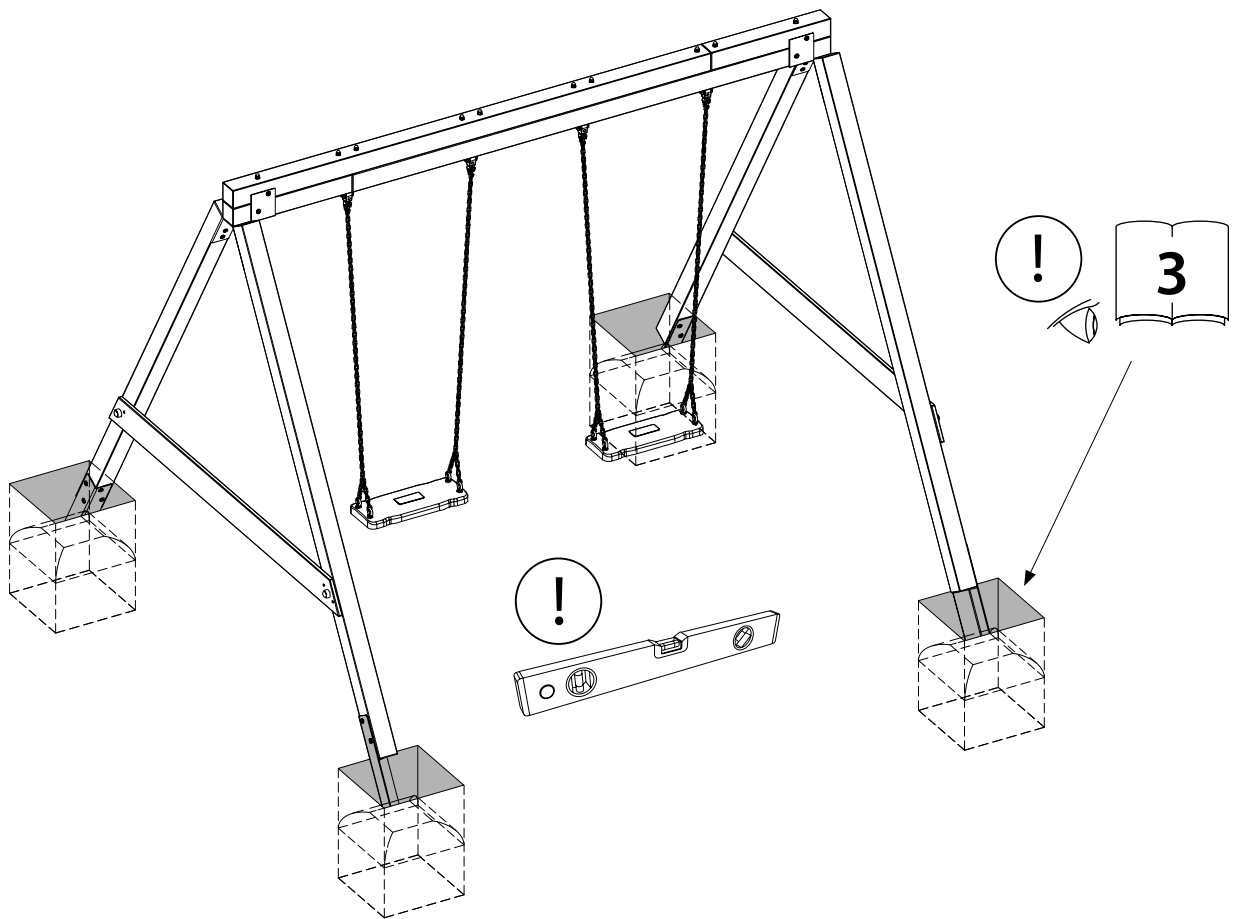

Ø5,5 x16



P17 x16

T80 x16

x4



Apila Sp. z o.o.
ul. Jagodowa 92, 62-002 Suchy Las, Poland
mob: +48 788 807 418
www.funforte.eu
cs@funforte.eu